



# STPM11/12/13/14

## Single phase energy metering IC with pulsed output and digital calibration

### Features

- Ripple free active energy pulsed output
- Direct stepper counter drivers
- Shunt, current transformer, Rogowsky coil sensors
- Live and neutral monitoring (STPM13/14)
- Easy and fast digital calibration at only one load point
- No-load, negative power and tamper indicators
- Integrated linear vregs
- RC (STPM11/13) or crystal oscillator (STPM12/14)
- Support 50÷60 Hz - IEC62052-11, IEC62053-2X specification
- Less than 0.1% error

### Description

The STPM1x family is designed for effective measurement of active energy in a power line system using a Rogowski Coil, current transformer and shunt sensors. This device is specifically designed to provide all the necessary features to implement a single phase energy meter without any other active component. The STPM1x device family consists, essentially, of two parts: the analog part and the digital part. The former, is composed of a preamplifier and first order  $\Sigma\Delta$  A/D converter blocks, band gap voltage reference, low drop voltage regulator. The digital part is composed of a system control, oscillator,

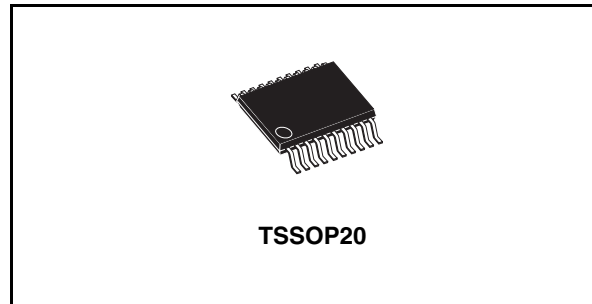

hard wired DSP and interface for calibration and configuration.

The calibration and configuration are done by OTP cells, that can be programmed through a serial interface. The configured bits are used for testing, configuration and calibration purposes. From two  $\Sigma\Delta$  output signals coming from the analog section, a DSP unit computes the amount of consumed active energy. The active energy is available as a pulse frequency output and directly driven by a stepper counter. In the STPM1x an output signal with pulse frequency proportional to energy is generated. This signal is used in the calibration phase of the energy meter application allowing a very easy approach. When the device is fully configured and calibrated, a dedicated bit of OTP block can be written permanently in order to prevent accidental entry into test mode or changing any configuration bit.

**Table 1. Device summary**

Order codes	Package	Packaging
STPM11ATR	TSSOP20 (tape and reel)	2500 parts per reel
STPM12ATR	TSSOP20 (tape and reel)	2500 parts per reel
STPM13ATR	TSSOP20 (tape and reel)	2500 parts per reel
STPM14ATR	TSSOP20 (tape and reel)	2500 parts per reel

# Contents

<b>1</b>	<b>Schematic diagram</b>	<b>6</b>
<b>2</b>	<b>Pin configuration</b>	<b>7</b>
<b>3</b>	<b>Maximum ratings</b>	<b>8</b>
<b>4</b>	<b>Electrical characteristics</b>	<b>9</b>
<b>5</b>	<b>Terminology</b>	<b>12</b>
5.1	Measurement error	12
5.2	ADC offset error	12
5.3	Gain error	12
5.4	Power supply DC and AC rejection	12
5.5	Conventions	12
<b>6</b>	<b>Typical performance characteristics</b>	<b>13</b>
<b>7</b>	<b>Theory of operation</b>	<b>15</b>
7.1	General operation	15
7.2	Analog inputs	15
7.3	$\Sigma\Delta$ A/D Converters	16
7.4	Period and line voltage measurement	17
7.5	Single wire meter mode (STPM13/14 with Rogowsky coil sensor)	18
7.6	Power supply	19
7.7	Load monitoring	20
7.8	Error detection	21
7.9	Tamper detection module (STPM13/14 only)	21
7.10	Phase compensation	23
7.11	Clock generator	23
7.12	Resetting the STPM1x	24
7.13	Energy to frequency conversion	24
7.14	Driving a stepper motor	25
7.15	Configuring the STPM1x	26

---

7.16	Mode signals .....	29
7.17	CFG1: Configuration interface .....	31
<b>8</b>	<b>Energy calculation algorithm .....</b>	<b>34</b>
<b>9</b>	<b>STPM1x calibration .....</b>	<b>37</b>
<b>10</b>	<b>Schematic .....</b>	<b>39</b>
<b>11</b>	<b>Package mechanical data .....</b>	<b>41</b>
<b>12</b>	<b>Revision history .....</b>	<b>44</b>

## List of figures

Figure 1.	Block diagram . . . . .	6
Figure 2.	Pin connections (top view) . . . . .	7
Figure 3.	Supply current vs supply voltage, $T_A = 25^\circ\text{C}$ . . . . .	13
Figure 4.	RC Oscillator frequency vs $V_{CC}$ , $R = 12\text{ k}\Omega$ , $T_A = 25^\circ\text{C}$ . . . . .	13
Figure 5.	RC oscillator: frequency jitter vs temperature. . . . .	13
Figure 6.	Analog voltage regulator: line - load regulation . . . . .	13
Figure 7.	Digital voltage regulator: line - load regulation . . . . .	13
Figure 8.	Voltage channel linearity at different $V_{CC}$ voltages. . . . .	13
Figure 9.	Power supply AC rejection vs $V_{CC}$ . . . . .	14
Figure 10.	Power supply DC rejection vs $V_{CC}$ . . . . .	14
Figure 11.	Error over dynamic range gain dependence. . . . .	14
Figure 12.	Primary current channel linearity at different $V_{CC}$ . . . . .	14
Figure 13.	Gain response of $\Delta \Sigma$ AD Converters . . . . .	14
Figure 14.	Clock frequency vs external resistor. . . . .	14
Figure 15.	First order $\Sigma \Delta$ A/D Converter . . . . .	17
Figure 16.	Bandgap temperature variation . . . . .	20
Figure 17.	Tamper conditions . . . . .	22
Figure 18.	Different oscillator circuits (a); (b); (c). . . . .	24
Figure 19.	Positive energy or absolute computation energy (ABS=1) stepper driving signals . . . . .	26
Figure 20.	Negative energy stepper driving signals. . . . .	26
Figure 21.	Timing for writing configuration and mode bits . . . . .	32
Figure 22.	Active energy computation diagram . . . . .	34
Figure 23.	Charge pump schematic. . . . .	39
Figure 24.	Application schematic. . . . .	40

## List of tables

Table 1.	Device summary . . . . .	1
Table 1.	Pin description . . . . .	7
Table 2.	Absolute maximum ratings (see note) . . . . .	8
Table 3.	Thermal data . . . . .	8
Table 4.	Electrical characteristics ( $V_{CC} = 5\text{ V}$ , $T_A = 25^\circ\text{C}$ , $2.2\ \mu\text{F}$ between $V_{DDA}$ and $V_{SS}$ , $2.2\ \mu\text{F}$ between $V_{DDD}$ and $V_{SS}$ , $2.2\ \mu\text{F}$ between $V_{CC}$ and $V_{SS}$ unless otherwise specified) . . . . .	9
Table 5.	Typical external components . . . . .	11
Table 9.	RMS voltage check . . . . .	18
Table 10.	Nominal voltage values . . . . .	18
Table 11.	No load detection thresholds . . . . .	20
Table 12.	Different settings for led signal . . . . .	25
Table 13.	Configuration of Mop and Mon Pins . . . . .	25
Table 14.	Configuration bits map . . . . .	27
Table 15.	Mode signals description . . . . .	30
Table 16.	Calibration entries . . . . .	37
Table 17.	Device calculation constants . . . . .	37
Table 18.	Calibration results . . . . .	38
Table 19.	Document revision history . . . . .	44

# 1 Schematic diagram

Figure 1. Block diagram

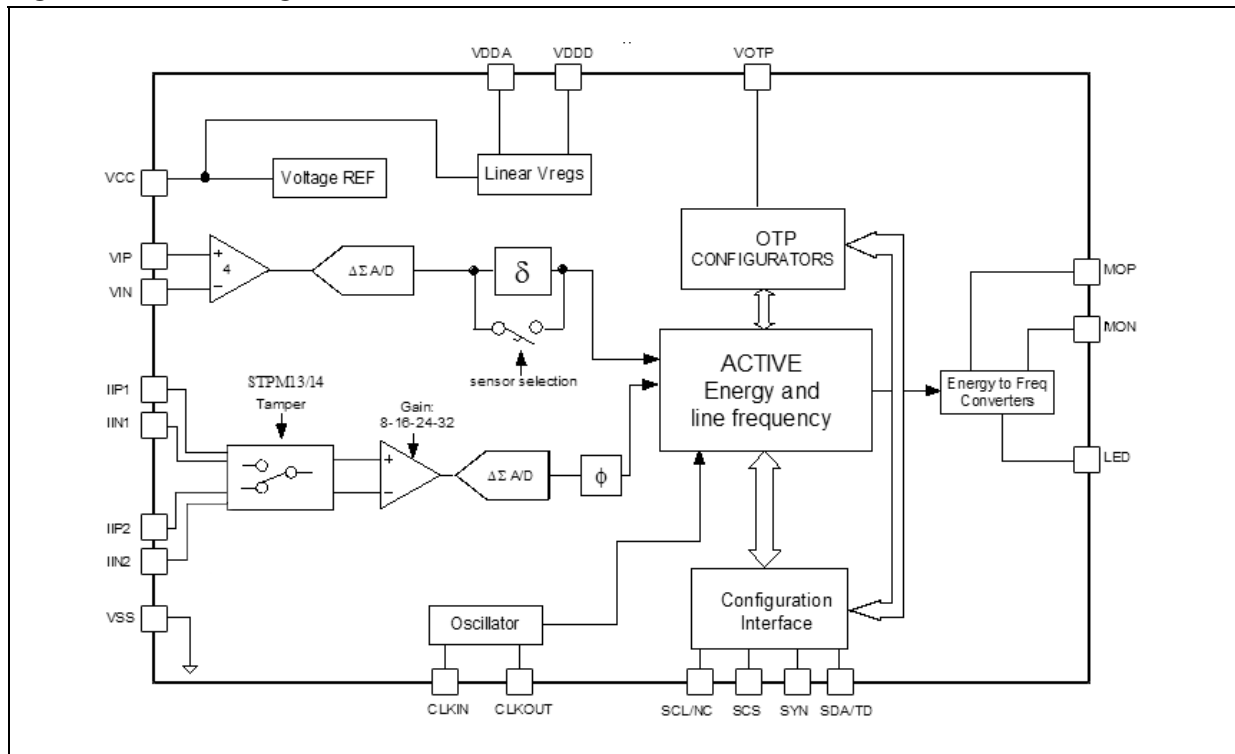

## 2 Pin configuration

Figure 2. Pin connections (top view)

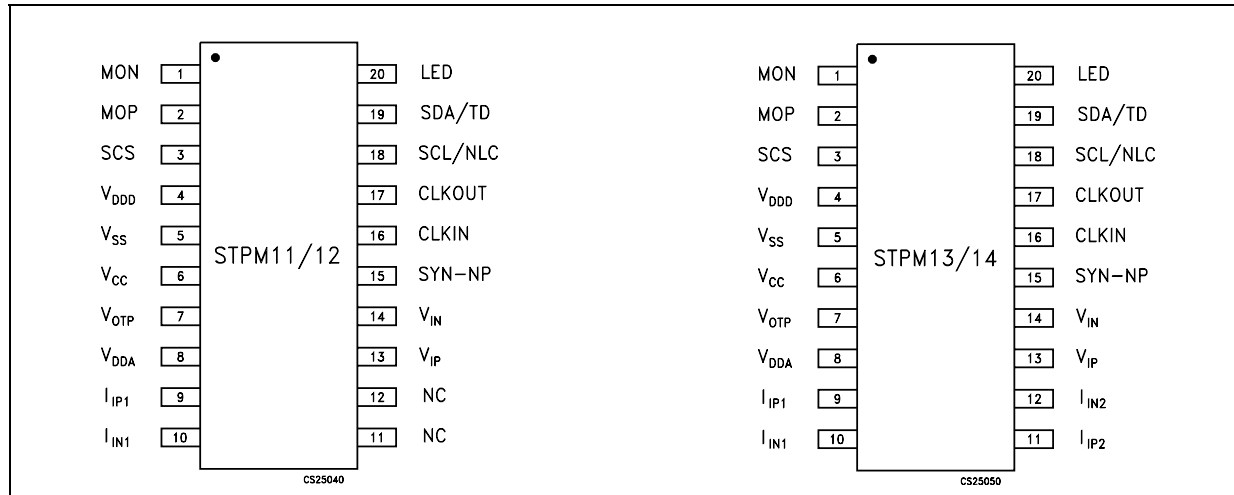

Table 1. Pin description

Pin n°	Symbol	Type <sup>(1)</sup>	Name and function
1	MON	P O	Output for Stepper's node
2	MOP	P O	Output for Stepper's node
3	SCS	D IN	Enable or disable configuration interface for device configuration.
4	V <sub>DDD</sub>	A OUT	1.5 V Output of internal low drop regulator which supplies the digital core.
5	V <sub>SS</sub>	GND	Ground.
6	V <sub>CC</sub>	P IN	Supply voltage.
7	V <sub>OTP</sub>	P INr	Supply voltage for OTP cells.
8	V <sub>DDA</sub>	A OUT	3 V output of internal low drop regulator which supplies the analog part.
9	I <sub>IP1</sub>	A IN	Positive input of primary current channel
10	I <sub>IN1</sub>	A IN	Negative input of primary current channel
11	I <sub>IP2</sub>	A IN	Positive input of secondary current channel (STPM13/14 only)
12	I <sub>IN2</sub>	A IN	Negative input of secondary current channel (STPM13/14 only)
13	V <sub>IP</sub>	A IN	Positive input of voltage channel
14	V <sub>IN</sub>	A IN	Negative input of voltage channel
15	SYN-NP	D I/O	Negative power indicator. (Configuration interface)
16	CLKIN	A IN	Crystal oscillator input or resistor connection if RC oscillator is selected
17	CLKOUT	A OUT	Oscillator output (RC or crystal)
18	SCL/NLC	D I/O	No-load condition indicator. (Configuration interface)
19	SDATD	D I/O	Tamper detection indicator. (Configuration interface)
20	LED	D O	Pulsed output proportional to active energy

1. A: Analog, D: Digital, P: Power

### 3 Maximum ratings

**Table 2. Absolute maximum ratings (see note)**

Symbol	Parameter	Value	Unit
$V_{CC}$	DC input voltage	-0.3 to 6	V
$I_{PIN}$	Current on any pin (sink/source)	$\pm 150$	mA
$V_{ID}$	Input voltage at digital pins (SCS, MOP, MON, SYN, SDATD, SCLNLC, LED)	-0.3 to $V_{CC}+0.3$	V
$V_{IA}$	Input voltage at analog pins ( $I_{IP1}$ , $I_{IN1}$ , $I_{IP2}$ , $I_{IN2}$ , $V_{IP}$ , $V_{IN}$ )	-0.7 to 0.7	V
$V_{OTP}$	Input voltage at OTP pin	-0.3 to 25	V
ESD	Human body model (all pins)	$\pm 3.5$	kV
$T_{OP}$	Operating ambient temperature	-40 to 85	°C
$T_J$	Junction temperature	-40 to 150	°C
$T_{STG}$	Storage temperature range	-55 to 150	°C

*Note: Absolute Maximum Ratings are those values beyond which damage to the device may occur. Functional operation under these condition is not implied*

**Table 3. Thermal data**

Symbol	Parameter	Value	Unit
$R_{thJA}$	Thermal resistance junction-ambient	114.5 <sup>(1)</sup>	°C/W

1. This value is referred to single-layer PCB, JEDEC standard test board.



## 4 Electrical characteristics

**Table 4. Electrical characteristics**

( $V_{CC} = 5\text{ V}$ ,  $T_A = 25^\circ\text{C}$ ,  $2.2\ \mu\text{F}$  between  $V_{DDA}$  and  $V_{SS}$ ,  $2.2\ \mu\text{F}$  between  $V_{DDD}$  and  $V_{SS}$ ,  $2.2\ \mu\text{F}$  between  $V_{CC}$  and  $V_{SS}$  unless otherwise specified)

Symbol	Parameter	Test conditions	Min.	Typ.	Max.	Unit
<b>Energy measurement accuracy</b>						
$f_{BW}$	Effective bandwidth	Limited by digital filtering	5		400	Hz
Error	Measurement error	Over the dynamic range (5% to 1000% of the calibration power value)		0.1		%
SNR	Signal to noise ratio	Over the entire bandwidth		52		db
PSRR <sub>DC</sub>	Power supply DC rejection	Voltage signal: $200\text{mV}_{rms}/50\text{Hz}$ Current signal: $10\text{mV}_{rms}/50\text{Hz}$ $f_{CLK} = 4.194\text{ MHz}$ $V_{CC} = 3.3\text{V} \pm 10\%$ , $5\text{ V} \pm 10\%$			0.2	%
PSRR <sub>AC</sub>	Power supply AC rejection	Voltage signal: $200\text{ mV}_{rms}/50\text{ Hz}$ Current signal: $10\text{ mV}_{rms}/50\text{ Hz}$ $f_{CLK} = 4.194\text{ MHz}$ , $V_{CC} = 3.3\text{ V} + 0.2\text{ V}_{rms1 @ 100\text{ Hz}}$ $V_{CC} = 5.0\text{ V} + 0.2\text{ V}_{rms1 @ 100\text{ Hz}}$			0.1	%
<b>General section</b>						
$V_{CC}$	Operating supply voltage		3.0		5.5	V
$I_{CC}$	Supply current configuration registers cleared or device locked (TSTD=1)	4 MHz, $V_{CC} = 5\text{ V}$		3.5	4	mA
		8 MHz, $V_{CC} = 5\text{ V}$		4.7	6	
$\Delta I_{CC}$	Increase of supply current per configuration bit, during programming	4 MHz, $V_{CC} = 5\text{ V}$		120		$\mu\text{A/bit}$
	Increase of supply current per configuration bit with device locked	4 MHz, $V_{CC} = 5\text{ V}$		2		
POR	Power on reset on $V_{CC}$			2.5		V
$V_{DDA}$	Analog supply voltage		2.85	3.0	3.15	V
$V_{DDD}$	Digital supply voltage		1.425	1.50	1.575	V
$f_{CLK}$	Oscillator clock frequency	MDIV bit = 0	4.000		4.194	MHz
		MDIV bit = 1	8.000		8.192	MHz
$f_{LINE}$	Nominal line frequency		45		65	Hz
$V_{OTP}$	OTP programming voltage		14		20	V
$I_{OTP}$	OTP programming current per bit			2.5		mA
$t_{OTP}$	OTP programming time per bit		100		300	$\mu\text{s}$

**Table 4. Electrical characteristics**

( $V_{CC} = 5\text{ V}$ ,  $T_A = 25^\circ\text{C}$ ,  $2.2\ \mu\text{F}$  between  $V_{DDA}$  and  $V_{SS}$ ,  $2.2\ \mu\text{F}$  between  $V_{DDD}$  and  $V_{SS}$ ,  $2.2\ \mu\text{F}$  between  $V_{CC}$  and  $V_{SS}$  unless otherwise specified)

Symbol	Parameter	Test conditions	Min.	Typ.	Max.	Unit	
$I_{LATCH}$	Current injection latch-up immunity				300	mA	
<b>Analog Inputs (<math>I_{IP1}</math>, <math>I_{IN1}</math>, <math>I_{IP2}</math>, <math>I_{IN2}</math>, <math>V_{IP}</math>, <math>V_{IN}</math>)</b>							
$V_{MAX}$	Maximum input signal levels	Voltage channel	-0.3		0.3	V	
		Current channels	Gain 8X	-0.15		0.15	V
			Gain 16X	-0.075		0.075	
			Gain 24X	-0.05		0.05	
			Gain 32X	-0.035		0.035	
$f_{ADC}$	A/D Converter bandwidth		10		KHz		
$f_{SPL}$	A/D Sampling frequency		$F_{CLK}/4$		Hz		
$V_{OFF}$	Amplifier offset			$\pm 20$	mV		
$Z_{IP}$	$V_{IP}$ , $V_{IN}$ Impedance	Over the total operating voltage range	100		400	K $\Omega$	
$Z_{IN}$	$V_{IP1}$ , $V_{IN1}$ , $V_{IP2}$ , $V_{IN2}$ Impedance	Over the total operating voltage range		100		K $\Omega$	
$G_{ERR}$	Current channels gain error			$\pm 10$		%	
$I_{ILV}$	Voltage channel leakage current		-1		1	$\mu\text{A}$	
$I_{LEAK}$	Current channel leakage current	Input disabled	-1		1	$\mu\text{A}$	
		Input enabled	-10		10		
<b>Digital I/O Characteristics (SDA-TD, CLKIN, CLKOUT, SCS, SYN-NP, LED)</b>							
$V_{IH}$	Input high voltage	SDA-TD, SCS, SYN-NP, LED	$0.75V_{CC}$			V	
		CLKIN	1.5				
$V_{IL}$	Input low voltage	SDA-TD, SCS, SYN-NP, LED			$0.25V_{CC}$	V	
		CLKIN			0.8		
$V_{OH}$	Output high voltage	$I_O = -2\text{ mA}$	$V_{CC}-0.4$			V	
$V_{OL}$	Output low voltage	$I_O = +2\text{ mA}$			0.4	V	
$I_{UP}$	Pull up current			15		$\mu\text{A}$	
$t_{TR}$	Transition time	$C_{LOAD} = 50\text{ pF}$		10		ns	
<b>Power I/O Characteristics (MOP, MON)</b>							
$V_{OH}$	Output high voltage	$I_O = -14\text{ mA}$	$V_{CC}-0.5$			V	
$V_{OL}$	Output low voltage	$I_O = +14\text{ mA}$			0.5	V	
$t_{TR}$	Transition time	$C_{LOAD} = 50\text{ pF}$	5	10		ns	
<b>Crystal oscillator (STPM12/14)</b>							

**Table 4. Electrical characteristics**

( $V_{CC} = 5\text{ V}$ ,  $T_A = 25^\circ\text{C}$ ,  $2.2\ \mu\text{F}$  between  $V_{DDA}$  and  $V_{SS}$ ,  $2.2\ \mu\text{F}$  between  $V_{DD}$  and  $V_{SS}$ ,  $2.2\ \mu\text{F}$  between  $V_{CC}$  and  $V_{SS}$  unless otherwise specified)

Symbol	Parameter	Test conditions	Min.	Typ.	Max.	Unit
$I_I$	Input current on CLKIN				$\pm 1$	$\mu\text{A}$
$R_P$	External resistor		1		4	$\text{M}\Omega$
$C_P$	External capacitors			22		$\text{pF}$
$f_{\text{CLK}}$	Nominal output frequency		4	4.194		MHz
			8	8.192		
<b>RC Oscillator (STPM11/13)</b>						
$I_{\text{CLKIN}}$	Settling current	$f_{\text{CLK}} = 4\text{ MHz}$	40		60	$\mu\text{A}$
$R_{\text{SET}}$	Settling resistor			12		$\text{k}\Omega$
$t_{\text{JIT}}$	Frequency jitter			1		ns
<b>On chip reference voltage</b>						
$V_{\text{REF}}$	Reference voltage			1.23		V
	Reference accuracy			$\pm 1$		%
$T_C$	Temperature coefficient	After calibration		30	50	$\text{ppm}/^\circ\text{C}$
<b>Configuration interface timing</b>						
$F_{\text{SCLKw}}$	Data write speed				100	KHz
$t_{\text{DS}}$	Data setup time		20			ns
$t_{\text{DH}}$	Data hold time		0			ns
$t_{\text{SYN}}$	SYN-NP active width		$2/f_{\text{CLK}}$			s

**Table 5. Typical external components**

Function	Component	Parameter	Value	Tolerance	Unit
Line voltage interface	Resistor divider	R to R ratio $V_{\text{RMS}} = 230\text{ V}$	1650	$\pm 1\%$	V/V
		R to R ratio $V_{\text{RMS}} = 110\text{ V}$	830	$\pm 1\%$	
Line current interface	Current shunt	Current to voltage conversion ratio	0.2	$\pm 5\%$	mV/A
	Current transformer		30	$\pm 12\%$	
	Rogowsky coil		3	$\pm 12\%$	

## 5 Terminology

### 5.1 Measurement error

The error associated with the energy measured by STPM1X is defined as:

$$\text{Percentage Error} = [\text{STPM1X (reading)} - \text{True Energy}] / \text{True Energy}$$

### 5.2 ADC offset error

This is the error due to the DC component associated with the analog inputs of the A/D converters. Due to the internal automatic DC offset cancellation, the STPM1X measurement is not affected by DC components in voltage and current channel. The DC offset cancellation is implemented in the DSP.

### 5.3 Gain error

The gain error is gain due to the signal channel gain amplifiers. This is the difference between the measured ADC code and the ideal output code. The difference is expressed as a percentage of the ideal code.

### 5.4 Power supply DC and AC rejection

This parameter quantifies the STPM1X measurement error as a percentage of the reading when the power supplies are varied. For the  $\text{PSRR}_{\text{AC}}$  measurement, a reading at two nominal supply voltages (3.3 and 5 V) is taken. A second reading is obtained with the same input signal levels when an ac (200 mV<sub>RMS</sub>/100 Hz) signal is introduced onto the supply voltages. Any error introduced by this ac signal is expressed as a percentage of reading.

For the  $\text{PSRR}_{\text{DC}}$  measurement, a reading at two nominal supply voltages (3.3 and 5 V) is taken. A second reading is obtained with the same input signal levels when the supplies are varied  $\pm 10\%$ . Any error introduced is again expressed as a percentage of the reading.

### 5.5 Conventions

The lowest analog and digital power supply voltage is named  $V_{\text{SS}}$  which represents the system Ground (GND). All voltage specifications for digital input/output pins are referred to GND.

Positive currents flow into a pin. Sinking current means that the current is flowing into the pin and is positive. Sourcing current means that the current is flowing out of the pin and is negative.

The timing specifications of the signal treated by digital control are relative to  $\text{CLK}_{\text{OUT}}$ . This signal is provided by from the crystal oscillator of 4.194MHz nominal frequency or by the internal RC oscillator. An external source of 4.194MHz or 8.192MHz can be used.

The timing specifications of signals of the CFGI interface are relative to the SCL-NLC, there is no direct relationship between the clock (SCL-NLC) of the CFGI interface and the clock of the DSP block.

A positive logic convention is used in all equations.

## 6 Typical performance characteristics

**Figure 3. Supply current vs supply voltage,  $T_A=25^\circ\text{C}$**

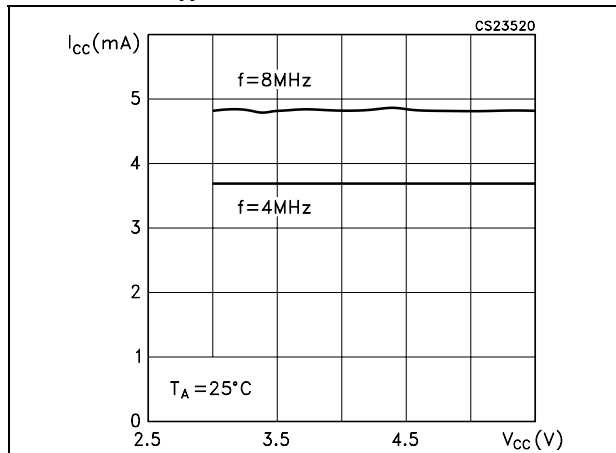

**Figure 4. RC Oscillator frequency vs  $V_{CC}$ ,  $R=12\text{ k}\Omega$ ,  $T_A=25^\circ\text{C}$**

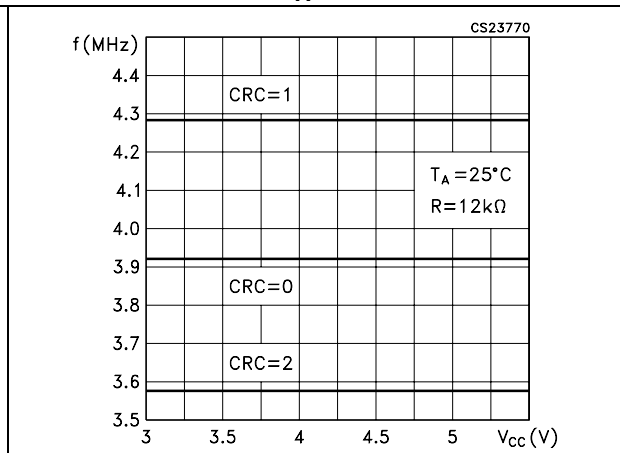

**Figure 5. RC oscillator: frequency jitter vs temperature**

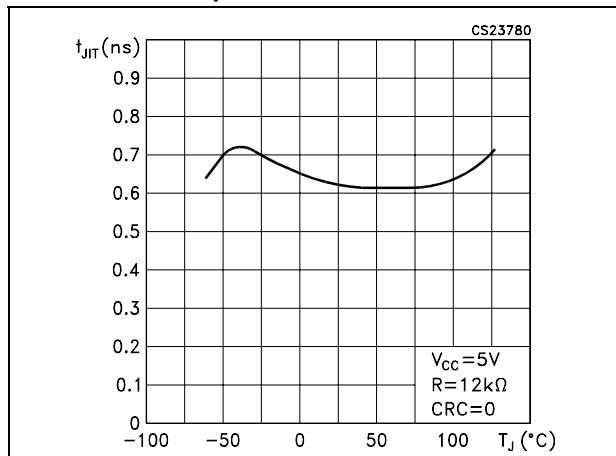

**Figure 6. Analog voltage regulator: line - load regulation**

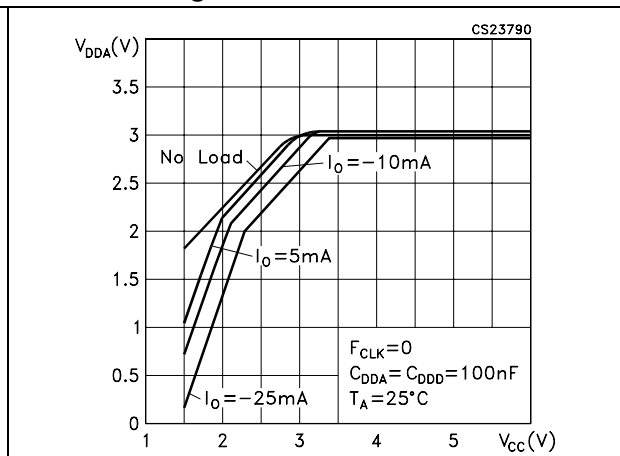

**Figure 7. Digital voltage regulator: line - load regulation**

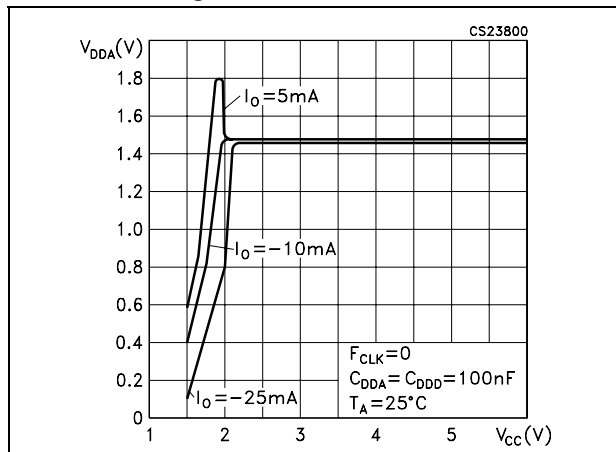

**Figure 8. Voltage channel linearity at different  $V_{CC}$  voltages**

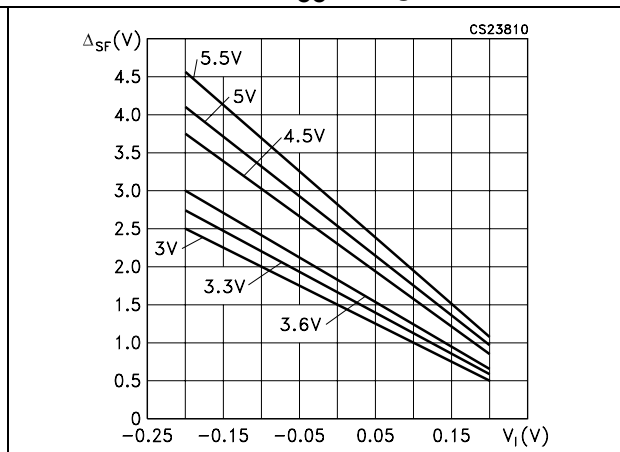

Figure 9. Power supply AC rejection vs  $V_{CC}$

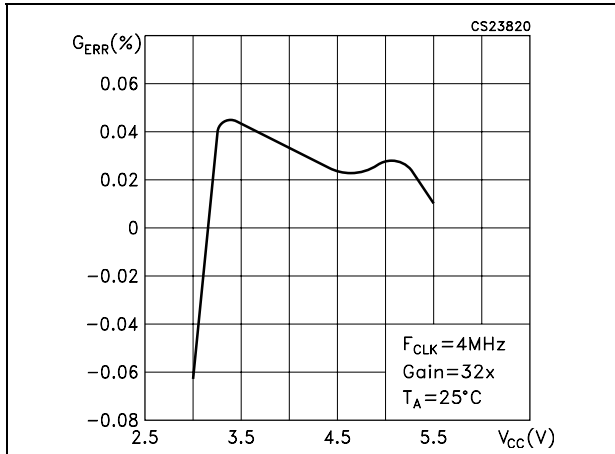

Figure 10. Power supply DC rejection vs  $V_{CC}$

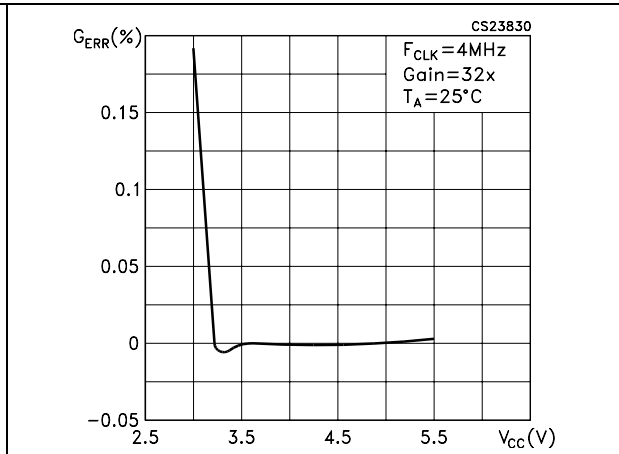

Figure 11. Error over dynamic range gain dependence

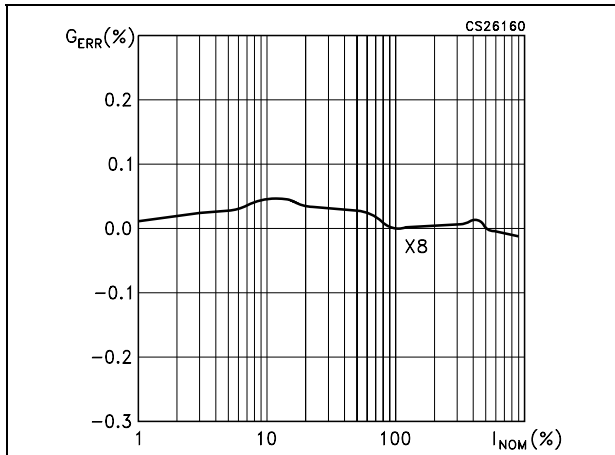

Figure 12. Primary current channel linearity at different  $V_{CC}$

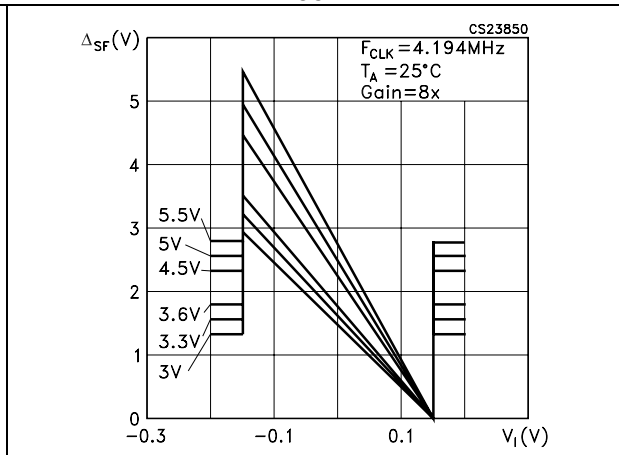

Figure 13. Gain response of  $\Delta\Sigma$  AD Converters

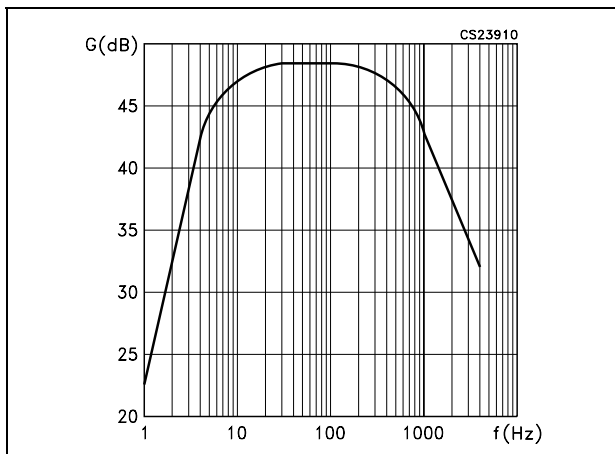
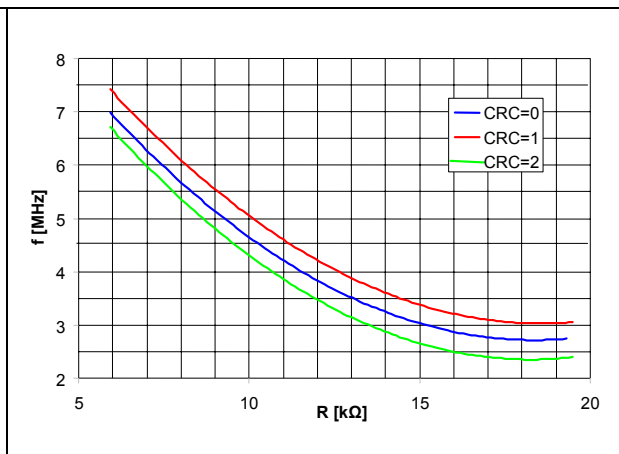

Figure 14. Clock frequency vs external resistor



## 7 Theory of operation

### 7.1 General operation

The STPM1X is able to perform active energy measurement (wide band or fundamental) in single-phase energy meter systems.

Due to the proprietary energy computation algorithm, STPM1X active energy is not affected by any ripple at twice the line frequency. The calibration is very easy and fast allowing calibration in only one point over the whole current range which allows saving time during the calibration phase of the meter. The calibration parameters are permanently stored in the OTP (one time programmable) cells, preventing calibration tampering.

Several functions are programmable using internal configuration bits accessible through the configuration interface. The most important configuration bits are two configuration bits called PST that allow the selection of the sensor and the gain of the input amplifiers.

The STPM1X is able to directly drive a stepper motor with the MOP and MON pins, and provides information on tamper, no-load and negative power.

Two kinds of active energy can be selected to be brought to the LED pin: the total active energy that includes all harmonic content up to 50<sup>th</sup> harmonic and the active energy limited to the 1<sup>st</sup> harmonic. This last energy value is obtained by filtering the wide band active energy.

### 7.2 Analog inputs

#### Input amplifiers

The STPM1X has one fully differential voltage input channel and one (STPM11/12) or two (STPM13/14) fully differential current input channels.

The voltage channel consists of a differential amplifier with a gain of 4. The maximum differential input voltage for the voltage channel is  $\pm 0.3$  V.

In STPM13/14, the two current channels are multiplexed (see tamper section for details) to provide a single input to a preamplifier with a gain of 4. The output of this preamplifier is connected to the input of a programmable gain amplifier (PGA) with possible gain selections of 2, 4, 6, 8. The total gain of the current channels will be then 8, 16, 24, 32. The gain selections are made by writing to the gain configuration bits PST and it can be different for the two current channels. The maximum differential input voltage is dependent on the selected gain according to the [Table 6](#):

**Table 6. Voltage channel**

Voltage channels		Current channels	
Gain	Max Input voltage (V)	Gain	Max input voltage (V)
4	$\pm 0.30$	8X	$\pm 0.15$
		16X	$\pm 0.075$
		24X	$\pm 0.05$
		32X	$\pm 0.035$

The [Table 7](#) and [Table 8](#): below show the gain values according to the configuration bits:

**Table 7. Configuration of current sensors**

STPM11/12			
Current channel		Configuration Bits	
Gain	Sensor	PST (2bits)	ADDG (1 bit)
8	Rogowsky Coil	0	0
16		0	1
24		1	0
32		1	1
8	CT	2	x
32	Shunt	3	x

**Table 8. Configuration of current sensors**

STPM13/14					
Primary		Secondary		Configuration Bits	
Gain	Sensor	Gain	Sensor	PST (2bits)	ADDG (1 bit)
8	Rogowsky Coil	8	Rogowsky Coil	0	0
16		16		0	1
24		24		1	0
32		32		1	1
8	CT	8	CT	2	x
8		32	Shunt	3	x

Both the voltage and current channels implement an active offset correction architecture which has the benefit of avoiding any offset compensation.

The analog voltage and current signals are processed by the  $\Sigma\Delta$  Analog to digital converters that feed the hardwired DSP. The DSP implements an automatic digital offset cancellation that makes possible avoiding any manual offset calibration on the analog inputs.

### 7.3 $\Sigma\Delta$ A/D Converters

The analog to digital conversion in the STPM1X is carried out using two first order  $\Sigma\Delta$  converters. The device performs A/D conversions of analog signals on two independent channels in parallel. In STPM13/14, the current channel is multiplexed as primary or secondary current channel in order to be able to perform a tamper function. The converted  $\Sigma\Delta$  signals are supplied to the internal hardwired DSP unit, which filters and integrates those signals in order to boost the resolution and to yield all the necessary signals for computations.

A  $\Sigma\Delta$  modulator converts the input signal into a continuous serial stream of 1s and 0s at a rate determined by the sampling clock. In the STPM1X, the sampling clock is equal to



$f_{CLK}/4$ . The 1-bit DAC in the feedback loop is driven by the serial data stream. The DAC output is subtracted from the input signal. If the loop gain is high enough, the average value of the DAC output (and therefore the bit stream) can approach that of the input signal level. When a large number of samples are averaged, a very precise value of the analog signal is obtained. This averaging is carried out in the DSP section which implements decimation, integration and DC offset cancellation of the supplied  $\Sigma\Delta$  signals. The gain of the decimation filters is 1.004 for the voltage channel and 0.502 for the current channel. The resulting signal has a resolution of 11bits for voltage channel and 16 bits for current channel.

**Figure 15. First order  $\Sigma\Delta$  A/D Converter**

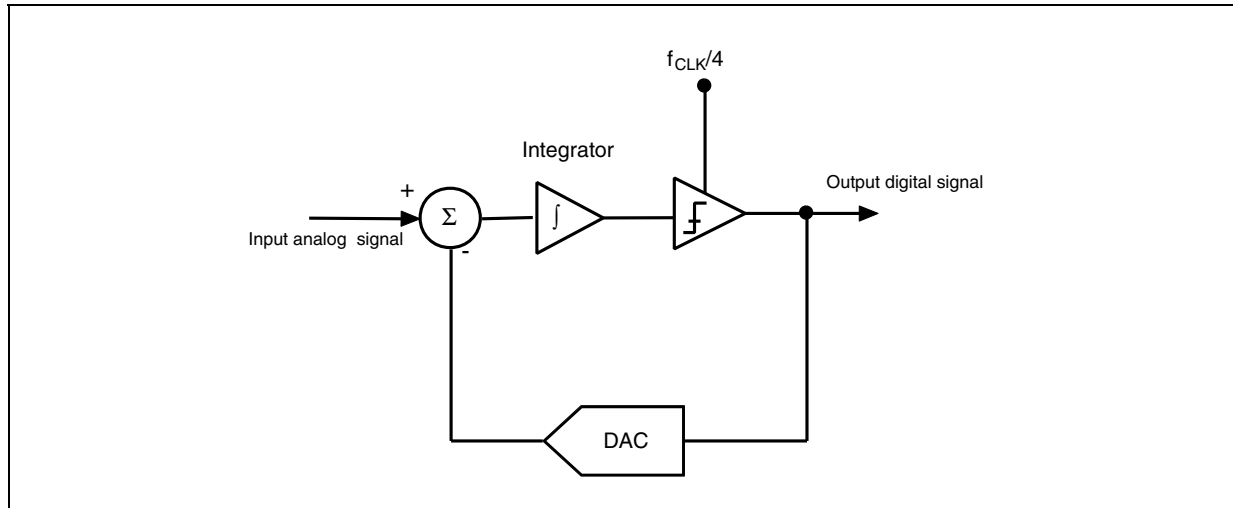

## 7.4 Period and line voltage measurement

The period module measures the period of base frequency of voltage channel and checks if the voltage signal frequency is in the band from  $f_{CLK}/2^{17}$  to  $f_{CLK}/2^{15}$ . An internal signal is produced at every positive peak of the line voltage. If the counted number of pulses between two trailing edges of this signal is higher than the  $f_{CLK}/2^{17}$  Hz equivalent pulses or if the counting is stopped (internal signal is not available), it means that the base frequency is lower than  $f_{CLK}/2^{17}$  Hz and an internal error flag BFR (Base Frequency Range) is set.

If the counted number of pulses within one line period is higher than the  $f_{CLK}/2^{15}$  equivalent pulses, the base frequency exceeds the limit. In this case, such error must be repeated three times in a row, in order to set the error flag BFR.

The BFR flag is also set if the value of the RMS voltage drops below a certain value (BFR-on) and it is cleared when the RMS voltage goes above BFR-off threshold. The table below shows the equivalent RMS voltage on the  $V_{IP}/V_{IN}$  pins according to the value of the voltage channel calibrator.

The BFR flag is also set if the RMS voltage across  $V_{IP}-V_{IN}$  drops below a threshold value calculated with the following formula:

$$V_{IRMS-BFR} = \frac{64}{6703 \cdot K_V}$$

(CT/Shunt)

$$V_{IRMS-BFR} = \frac{64}{6687 \cdot K_V}$$

(Rogowsky)

Where  $K_V$  is the voltage calibrator value ranging from 0.875 to 1.000.

The BFR flag is cleared when the  $V_{IRMS}$  value goes above twice  $V_{IRMS-BFR}$ . When the BFR error is set, the computation of power is suspended and MOP, MON and LED will be held low.

**Table 9. RMS voltage check**

	BFR-on	BFR-off
Rogowsky	0.009571/Kv	0.019142/Kv
CT-Shunt	0.0078/Kv	0.0156/Kv

## 7.5 Single wire meter mode (STPM13/14 with Rogowsky coil sensor)

STPM1X supports the Single Wire Meter (SWM) operation when working with Rogowsky Coil current sensors. In SWM mode there is no available voltage information in the voltage channel. It is possible that someone has disconnected one wire (live or neutral) of the meter for tampering purposes or in case the line voltage is very stable, it is possible to use a predefined value for computing the energy without sensing it.

In order to enable the SWM mode, the STPM1X must be configured with PST values of 0 or 1. In this way, if the BFR error is detected, STPM1X enters in SWM. If BFR is cleared, the energy calculation is performed normally. When BFR is set (no voltage information is available), the energy computation is carried out using a nominal voltage value according to the NOM configuration bits.

Since there is no information on the phase shift between voltage and current, the apparent rather than active power is used for tamper and energy computation. The calculated apparent energy will be the product between  $I_{RMS}$  (effectively measured) and an equivalent  $V_{RMS}$  that can be calculated as follows:

$V_{RMS} = V_{PK} \cdot K_{NOM}$ , where  $V_{PK}$  represents the maximum line voltage reading of the STPM1X and  $K_{NOM}$  is a coefficient that changes according to [Table 10](#):

**Table 10. Nominal voltage values**

NOM	$K_{NOM}$
0	0.3594
1	0.3906
2	0.4219
3	0.4531

For example, if  $R_1 = 783\text{k}\Omega$  and  $R_2 = 475\Omega$  are used as resistor divider when the line voltage is present, the positive voltage present at the input of the voltage channel of STPM1x is:

$$VI = \frac{R_2}{R_1 + R_2} \cdot V_{RMS} \sqrt{2}$$

since the maximum voltage value applicable to the voltage channel input of STPM1x is +0.3V, the equivalent maximum line voltage applicable is:

$$V_{PK} = R_1 + R_2 / R_2 \cdot 0.3 = 494.82$$

considering the case of  $NOM=2$ , the correspondent RMS values used for energy computation is:

$$V_{RMS} = V_{PK} \cdot 0.4219 = 208.76 \text{ [V]}$$

Usually the supply voltage for the electronic meter is taken from the line voltage. In SWM, since the line voltage is no longer present, another power source must be used in order to provide the necessary supply to STPM1x and the other electronic components of the meter.

## 7.6 Power supply

The main STPM1X supply pin is the  $V_{CC}$  pin. From the  $V_{CC}$  pin two linear regulators provide the necessary voltage for the analog part  $V_{DDA}$  (3 V) and for the digital part  $V_{DDD}$  (1.5 V). The  $V_{SS}$  pin represents the reference point for all the internal signals. The 100nF capacitor should be connected between  $V_{CC}$  and  $V_{SS}$ ,  $V_{DDA}$  and  $V_{SS}$ ,  $V_{DDD}$  and  $V_{SS}$ . All these capacitors must be located very close to the device.

The STPM1X contains a Power-On-Reset (POR) detection circuit. If the  $V_{CC}$  supply is less than 2.5 V, then the STPM1X goes into an inactive state, all the functions are blocked asserting and a reset condition is set. This is useful to ensure that the correct device operation at power-up and during power-down. The power supply monitor has built-in hysteresis and filtering, which give a high degree of immunity to false triggering due to noisy supply voltages.

A BandGap voltage reference (VBG) of  $1.23 \text{ V} \pm 1\%$  is used as reference voltage level source for the two linear regulators and for the A/D converters. Also, this module produces several bias currents and voltages for all other analog modules and for the OTP module. The bandgap voltage temperature behavior can be changed in order to better compensate the variation of sensor sensitivity with temperature. This task is performed with the BGTC configuration bits.

Figure 16. Bandgap temperature variation

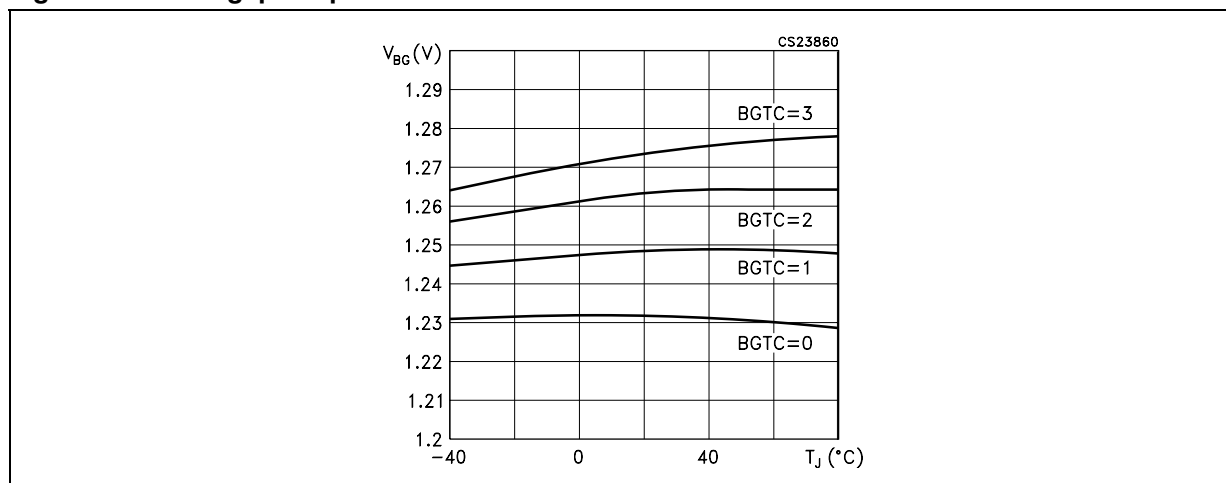

## 7.7 Load monitoring

The STPM1X include a no-load condition detection circuit with adjustable threshold. This circuit monitors the voltage and the current channels and, when the measured power is below the set threshold, the internal signal BIL becomes high. The information about this signal is also available in the status bit BIL.

The no load condition occurs when the product between V<sub>RMS</sub> and I<sub>RMS</sub> input values is below a given value. This value can be set with the LTCH configuration bits, and it is also dependent on the selected current gain (A<sub>i</sub>) and the calibration registers constant K<sub>p</sub>=K<sub>v</sub>\*K<sub>i</sub>.

Four different no-load threshold values can be chosen according to the two configurations bits LTCH (see [Table 11](#)).

Table 11. No load detection thresholds

LTCH	V <sub>rms</sub> * I <sub>rms</sub> (input channel voltages)	
	Rogowski coil (PST<2)	Ct or Shunt (PST>1)
0	0.004488 / (A <sub>i</sub> *K <sub>p</sub> )	0.003648 / (A <sub>i</sub> *K <sub>p</sub> )
1	0.008976 / (A <sub>i</sub> *K <sub>p</sub> )	0.007296 / (A <sub>i</sub> *K <sub>p</sub> )
2	0.017952 / (A <sub>i</sub> *K <sub>p</sub> )	0.014592 / (A <sub>i</sub> *K <sub>p</sub> )
3	0.035904 / (A <sub>i</sub> *K <sub>p</sub> )	0.029184 / (A <sub>i</sub> *K <sub>p</sub> )

When a no-load condition occurs (BIL=1), the integration of power is suspended and the tamper module is disabled.

If a no-load condition is detected, the BIL signal blocks generation of pulses for stepper and forces the SCLNLC pin to be low.

## 7.8 Error detection

In addition to the no-load condition and the line frequency band, the integration of power can be suspended also due to detected error on the source signals.

There are two kinds of error detection circuits involved. The first checks all the  $\Sigma\Delta$  signals from the analog part if any are stacked at 1 or 0 within the  $1/128$  of  $f_{CLK}$  period of observation. In case of detected error the corresponding  $\Sigma\Delta$  signal is replaced with an idle  $\Sigma\Delta$  signal, which represents a constant value 0.

Another error condition occurs if the MOP, MON and LED pin outputs signals are different from the internal signals that drive them. This can occur if some of this pin is forced to GND or to some other imposed voltage value.

## 7.9 Tamper detection module (STPM13/14 only)

The STPM13/14 is able to measure the current in both live and neutral wires. This mechanism has been adapted to implement an anti-tamper function. If this function is selected (see [Table 8](#)), the live and neutral wire currents are monitored. When a difference between the two measurements is detected, the STPM13/14 enters the Tamper State. When there is a very small difference between the two channels, the STPM13/14 is in Normal state.

In particular, both channels are not constantly observed. A time multiplex mechanism is used. During the observation time of the selected channel, its active energy is calculated. The detection of a tamper condition occurs when the absolute value of the difference between the two active energy values is greater than a certain percentage of the averaged energy during the activated tamper module. This percentage value can be selected between two different values (12.5% and 6.25%) according to the value of the configuration bit CRIT.

The tamper condition will be detected when the following formula is satisfied:

$\text{EnergyCH1} - \text{EnergyCH2} > K_{\text{CRIT}} (\text{EnergyCH1} + \text{EnergyCH2})/2$ ; where  $K_{\text{CRIT}}$  can be 12.5% or 6.25%.

The detection threshold is much higher than the accuracy difference of the current channels, which should be less than 0.1%. Some margin should be left for a possible transition effect, due to accidental synchronism between the actual load current change and the rhythm of taking the energy samples.

The tamper circuit works if the energies associated with the two current channels will be both positive or both negative. If the two energies have different signs, the tamper remains on constantly. However, the channel with the associated higher power is selected for the final computation of energy.

In single wire mode, the Apparent energy rather than active is used for Tamper detection.

### Detailed operational description

#### Normal state

The meter is initially set to normal state, i.e. tamper not detected. In such state, we expect that the values of both load currents should not differ more than the accuracy difference of the channels. For this reason, we can use an average value of currents of both channels for the active energy calculation. The average is implemented with the multiplex ratio of 32:32 periods of line per channel. This means that for 32 periods of line voltage, i.e. 640ms at 50 Hz, the current of the primary channel is used for the calculation followed by another 32

periods of line voltage when the current of secondary channel is used instead. Four periods before the primary to secondary switching point, a tamper detection module is activated. It is deactivated after eight periods of line have elapsed. This means that energy of four periods of primary channel immediately followed by energy of four periods of secondary channel is sampled within the tamper module. We shall call those samples A and B respectively. From these two samples the criteria of tamper detection is calculated. If four consecutive new results of criteria happen, i.e. after elapsed 5.12s at 50 Hz, the meter will enter into Tamper State

### Tamper State

Within this state the multiplex ratio will change either to 60:4, when primary current is higher than secondary, or to 4:60 otherwise. Thus, the channel with the higher current is used in the energy calculation. The energy is not averaged by the mentioned ratio, rather the last measured higher current is used also during 4 line period gap. The gap is still needed in order to monitor the samples of the non-selected channel, which should check when the tamper detected state is changed to either normal or another tamper detected state.

Several cases of transition of the state are shown in the [Figure 17](#) - below

**Figure 17. Tamper conditions**

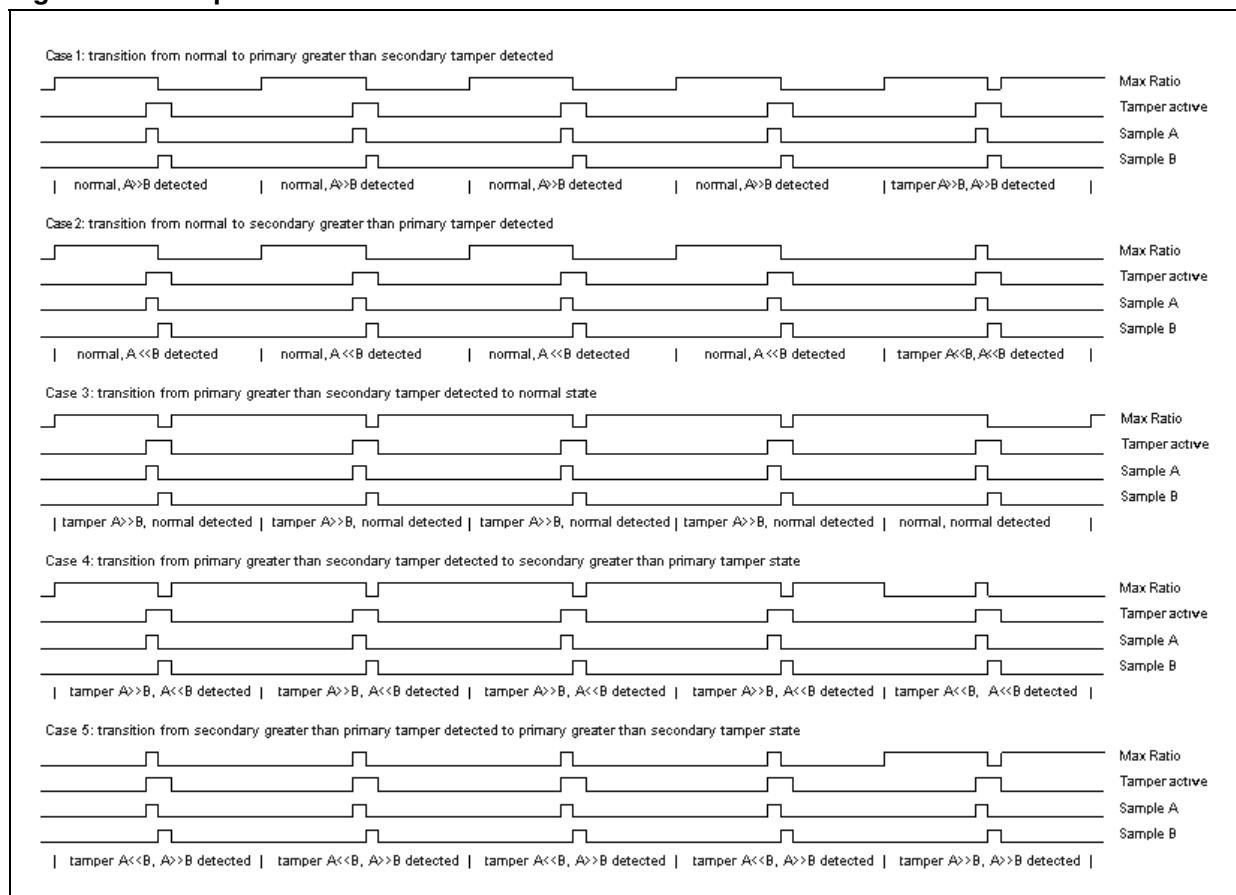

The detected tamper condition is stored in the BIT signal. This signal is connected to the SDA-TD pin. When this pin is low, a tamper condition has been detected.

When internal signals are not good enough to perform the computation, i.e. line period is out of range or  $\Sigma$  signals from the analog part are stacked at high or low logic level, or no load condition is activated, the tamper module is disabled and its state is preset to normal.

## 7.10 Phase compensation

The STPM1X does not introduce any phase shift between voltage and current channels.

However, the voltage and current signals come from transducers, which could have inherent phase errors. For example, a phase error of  $0.1^\circ$  to  $0.3^\circ$  is not uncommon for a current transformer (CT). These phase errors can vary from part to part, and they must be corrected in order to perform accurate power calculations. The errors associated with phase mismatch are particularly noticeable at low power factors. The STPM1x provide a means of digitally calibrating these small phase errors through a introducing delays on the voltage or current signal. The amount of phase compensation can be set using the 4 bits of the phase calibration register (CPH).

The default value of this register is at a value of 0 which gives  $0^\circ$  phase compensation. A CPH value of 15 (1111) introduces a phase compensation of  $+0.576^\circ$ . This compensates the phase shift usually introduced by the current sensor, while the voltage sensor, normally a resistor divider, does not introduce any delay. The resolution step of the phase compensation is  $0.038^\circ$ .

## 7.11 Clock generator

All the internal timing of the STPM1X is based on the  $CLK_{OUT}$  signal. This signal is generated by different circuits according to the STPM1x version.

STPM11/13: Internal RC Oscillator. A resistor connected between  $CLK_{IN}$  and Ground will set the RC current. For 4 MHz operation the suggested settling resistor is 12 k $\Omega$ . The oscillator frequency can be compensated using the CRC configuration bit (see [Table 13](#) and [Figure 14](#))

STPM12/14: Quartz Oscillator. The oscillator circuit is designed to support an external crystal. The suggested circuit is depicted in [Figure 18](#). These versions support also an external oscillator signal source that must be connected to the  $CLK_{OUT}$  pin.

The clock generator is powered from analog supply and is responsible for two tasks. The first one is to retard the turn-on of some function blocks after POR in order to help smooth start of external power supply circuitry by keeping all major loads off.

The second task of the clock generator is to provide all necessary clocks for analog and digital parts. Within this task, the MDIV configuration bit is used to inform the device about the nominal frequency value of  $CLK_{OUT}$ . The suggested operation frequency range is from 4.000 MHz to 4.194 MHz.

Figure 18. Different oscillator circuits (a); (b); (c)

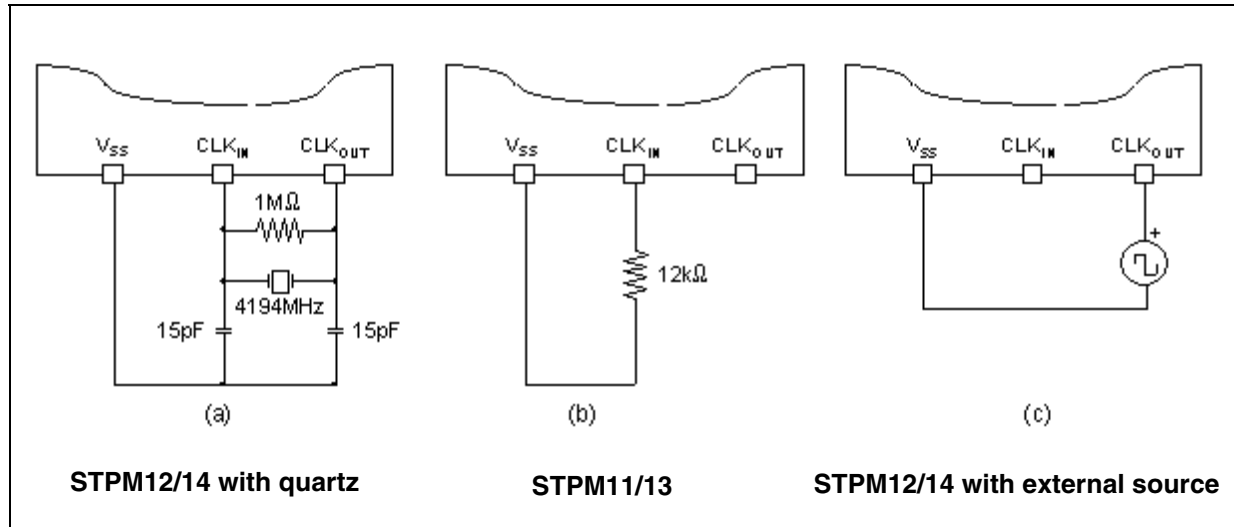

## 7.12 Resetting the STPM1x

The STPM1x has no reset pin. The device is automatically reset by the POR circuit when the  $V_{CC}$  crosses the 2.5 V value. When the reset occurs, all clocks and both DC buffers in the analog part are kept off for about 30ms and all blocks of the digital part are held in a reset state for about 125 ms after a reset condition.

Resetting the STPM1x causes all the functional modules of STPM1x to be cleared including the OTP shadow latches (see 7.15 for OTP shadow latches description)

## 7.13 Energy to frequency conversion

The STPM1x provides energy to frequency conversion both for calibration and energy readout purposes. In fact, one convenient way to verify the meter calibration is to provide a pulse train signal with 50% duty cycle whose frequency signal is proportional to the active energy under steady load conditions. It is convenient to have high frequency pulses during calibration phase and low frequency for readout purposes; STPM1x supports both cases. Let's suppose to choose a certain number of pulses on the LED pin (high frequency) that will corresponds to 1 kWh. We will name this value as P.

The Active Energy frequency-based signal is available in the LED pin. The LED is driven from internal signal AW (Active Energy) whose frequency is proportional to the active energy. The desired P is achieved acting on the digital calibrators during the calibration procedure.

The APL configuration bit changes the internal divider that provides the signal on the LED pin according to [Table 12](#), setting APL=1 the number of pulses are reduced in order to provide low frequency pulses for readout purposes. The division factor is set according to KMOT configuration bits. In this case the pulses will have a fixed width of 31.25 ms.



**Table 12. Different settings for led signal**

KMOT (2 Bits)	APL=0	APL=1
	Pulses	Pulses
0	P	P/64
1		P/128
2		P/32
3		P/256

Due to the innovative and proprietary power calculation algorithm, the frequency signal is not affected by any ripple at twice the line frequency. This feature strongly reduces the calibration time of the meter.

## 7.14 Driving a stepper motor

The STPM1x is able to directly drive a stepper motor. An internal divider (mono-flop and decoder) generates stepper driving signals MA and MB from signal AW. The MA and MB signals are brought to the MOP and MON pins that are able to drive the stepper motor. Several kinds of selections are possible for the driving signals according to the configuration bits LVS and KMOT.

The numbers of pulses per kWh (PM) in the MOP and MON outputs are linked with the number of pulses of the LED P (see previous paragraph - 7.13) pin with the following relationship.

**Table 13. Configuration of Mop and Mon Pins**

LVS (1 Bit)	KMOT (2 Bits)	Pulses length	PM
0	0	31.25 ms	P/64
0	1	31.25 ms	P/128
0	2	31.25 ms	P/32
0	3	31.25 ms	P/256
1	0	156.25 ms	P/640
1	1	156.25 ms	P/1280
1	2	156.25 ms	P/320
1	3	156.25 ms	P/2560

The mono-flop limits the length of the pulses according to the LVS bit value.

The decoder distributes the pulses to MA and MB alternatively, which means that each of them has only one half of selected frequency.

In case of detected negative power the behavior of MOP and MON depends on the ABS configuration bit status. If this bit is set, the negative power is computed as it was positive (absolute value), and the MOP and MON signals maintain the pulse sequence in order to keep the forward rotation direction of the motor. If ABS is zero, negative power is computed with its own sign, and the MOP and MON signals invert their logic state in order to make the backward rotation direction of the motor. See the diagram below.

Figure 19. Positive energy or absolute computation energy (ABS=1) stepper driving signals

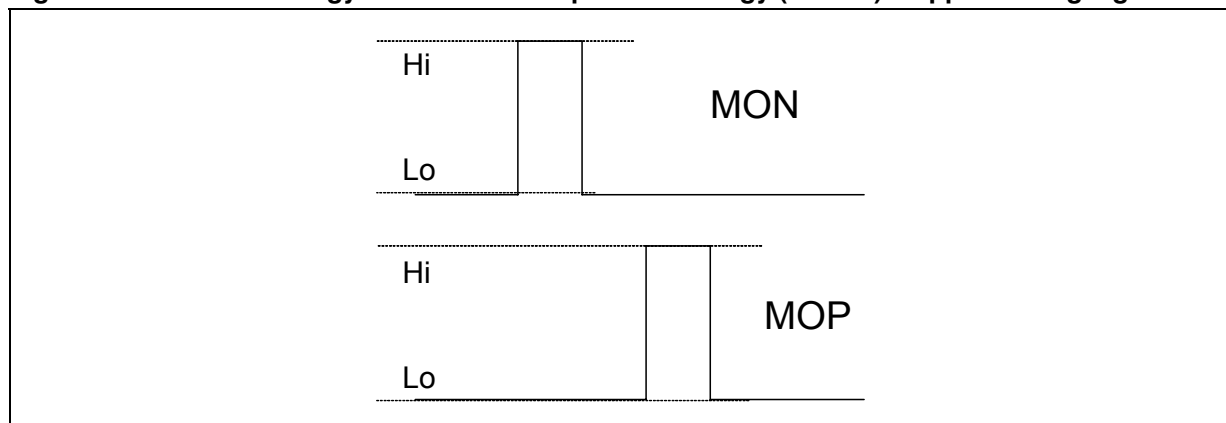
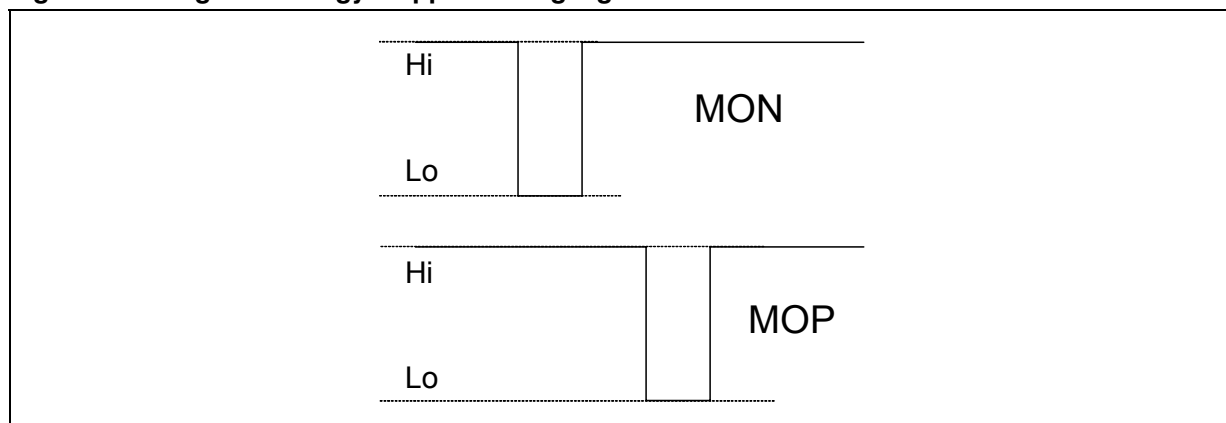

Figure 20. Negative energy stepper driving signals



When a no-load condition is detected MOP and MON are held low.

## 7.15 Configuring the STPM1x

All the configuration bits that control the operation of the device can be written temporarily or permanently. For temporary writing, the configuration bits value are written in the Shadow Registers which are simple latches that hold the configuration data. For permanent writing, the configuration bits are stored in the OTP (one time programmable) cells that keep the information for an undefined period of time even if the STPM1X is without supply, but, once written, they cannot be changed. The temporary writing is useful mainly during testing of the device or during the calibration phase. All the configuration parameters can be changed an infinite number of times in order to test the device operation.

The shadow registers are cleared whenever a reset condition occurs.

The configuration bits are different for STPM11/12 and for STPM13/14 due to the presence of the Tamper module. Each of them consists of paired elements, one is latch (the OTP shadow), and one is the OTP anti-fuse element. When the STPM1X is released in the market, all anti-fuses represent logic low state but they can be written by the user in order to configure the STPM1X. This means that STPM1X can retain these bits of information even if it has been unsupplied for an undefined time. That's why the CFG signals are used to keep certain configuration and calibration values of the device.

The very first CFG bit, called TSTD, is used to disable any change of system signals after it has been permanently set. During the configuration phase, each bit set to logic level 1 increases the supply current of STPM01 of about 120  $\mu\text{A}$ , until the TSTD bit is set to 1. The residual increase of supply current is 2  $\mu\text{A}$  per each bit set to 1. It is then recommended to set the TSTD bit to 1 after the configuration procedure in order to keep the supply current as low as possible.

The STPM1x can work either using the data stored in the OTP cells or the data available in the shadow latches. This can be chosen according to the value RD Mode signal (see paragraph 7.16 for description). If the RD is set, the CFG bits originates from corresponding OTP shadow latches. If the RD is cleared, the CFG bits originates from corresponding OTP anti-fuses. In this way, it is possible to temporarily set up certain configurations or calibrations of the device then verify and change, if necessary. This exercise is extensively used during production tests.

Each configuration bit can be written sending a byte command to STPM1x through its configuration interface. The procedure to write the configuration bits is described in the Configuration Interface section (7.17).

After the TSTD bit has been set, no other command can be sent to the STPM1x. This implies that the shadow latches can no longer be used as source of configuration data.

**Table 14. Configuration bits map**

Address		Name	N. of bits	DESCRIPTION <sup>(1)</sup>
6-BIT Binary	DEC			
000000	0	TSTD	1	Test mode and OTP write disable: - TSTD=0: testing and continuous pre-charge of OTP when in read mode, - TSTD=1: normal operation and no more writes to OTP
000001	1	MDIV	1	Measurement frequency range selection: - MDIV=0: 4.000MHz to 4.194MHz, - MDIV=1: 8.000MHz to 8.192MHz
000011	3	APL	1	LED pin frequency output: - APL=0: P - APL=1: KMOT=0 $\rightarrow$ P/64 KMOT=1 $\rightarrow$ P/128 KMOT=2 $\rightarrow$ P/32 KMOT=3 $\rightarrow$ P/256
000101	5	PST	2	Current channel sensor type, gain and tamper selection: STPM11/12 - PST=0: primary is Rogowsky coil x8 (x16 if ADDG=1) - PST=1: primary is Rogowsky coil x24 (x32 if ADDG=1), - PST=2: primary is CT x8, - PST=3: primary is shunt x32, STPM13/14 - PST=0: primary is Rogowsky coil x8 (x16 if ADDG=1), secondary is Rogowsky coil x8 (x16 if ADDG=1), - PST=1: primary is Rogowsky coil x24 (x32 if ADDG=1), secondary is Rogowsky coil x24 (x32 if ADDG=1), - PST=2: primary is CT x8, secondary is CT x8 - PST=3: primary is CT x8, secondary is shunt x32
000110	6 <sup>(1)</sup>			

Table 14. Configuration bits map (continued)

Address		Name	N. of bits	DESCRIPTION <sup>(1)</sup>
6-BIT Binary	DEC			
001010	10	FUND	1	This bit swaps the energy type between fundamental or wide band. - FUND=0: wide band active energy up to 50 <sup>th</sup> harmonic; - FUND=1: fundamental active energy
001011	11	ABS	1	Power accumulation type selection: - ABS=0: signed accumulation, - ABS=1: absolute accumulation
001100	12	LTCH	2	No-load condition constant: LTCH=0 →800 LTCH=1 →1600 LTCH=2 →3200 LTCH=3 →6400
001101	13 <sup>(1)</sup>			
001110	14	KMOT	2	Constant of stepper pulses/kWh (see par. 7.14) selection: If LVS=0, KMOT=0 →P/64 KMOT=1 →P/128 KMOT=2 →P/32 KMOT=3 →P/256
001111	15 <sup>(1)</sup>			
010010	18	BGTC	2	Bandgap temperature compensation bits. See <a href="#">Figure 16</a> . for details.
010011	19 <sup>(1)</sup>			
010100	20	CPH	4	4-bit unsigned data for compensation of phase error, 0°+0.576° 16 values are possible with a compensation step of 0.0384°. When CPH=0 the compensation is 0°, when CPH=15 the compensation is 0.576°.
010101	21			
010110	22			
010111	23 <sup>(1)</sup>			
011000	24	CHV	8	8-bit unsigned data for voltage channel calibration. 256 values are possible. When CHV is 0 the calibrator is at -12.5% of the nominal value. When CHV is 255 the calibrator is at +12.5%. The calibration step is then 0.098%.
011001	25			
011010	26			
011011	27			
011100	28			
011101	29			
011110	30			
011111	31 <sup>(1)</sup>			

Table 14. Configuration bits map (continued)

Address		Name	N. of bits	DESCRIPTION <sup>(1)</sup>
6-BIT Binary	DEC			
100000	32	CHP	8	8-bit unsigned data for primary current channel calibration. 256 values are possible. When CHP is 0 the calibrator is at -12.5% of the nominal value. When CHP is 255 the calibrator is at +12.5%. The calibration step is then 0.098%.
100001	33			
100010	34			
100011	35			
100100	36			
100101	37			
100110	38			
100111	39 <sup>(1)</sup>			
101000	40	CHS	8	STPM13/14 only 8-bit unsigned data for secondary current channel calibration. 256 values are possible. When CHS is 0 the calibrator is at -12.5% of the nominal value. When CHS is 255 the calibrator is at +12.5%. The calibration step is then 0.098%.
101001	41			
101010	42			
101011	43			
101100	44			
101101	45			
101110	46			
101111	47 <sup>(1)</sup>			
110000	48	CRC	2	STPM11/13 only 2-bit unsigned data for calibration of RC oscillator. (see Typical characteristics in) CRC=0, or CRC=3 cal=0% CRC=1, cal=+10%; CRC=2, cal=-10%
110001	49 <sup>(1)</sup>			
110010	50	NOM	2	2-bit modifier of nominal voltage for Single Wire Meter. NOM=0: $K_{NOM}=0.3594$ / NOM=1: $K_{NOM}=0.3906$ / NOM=2: $K_{NOM}=0.4219$ / NOM=3: $K_{NOM}=0.4531$
110011	51 <sup>(1)</sup>			
110100	52	ADDG	1	Selection of additional gain on current channels: ADDG=0: Gain+=0 / ADDG=1: Gain+=8
110101	53	CRIT	1	STPM13/14 only Selection of tamper threshold: CRIT =0: 12,5% / CRIT =1: 6,25%
110110	54	LVS	1	Type of stepper selection: LVS=0: pulse width 31.25 ms, 5V, / LVS=1: pulse width, 156.25 ms, 3V

1. IMPORTANT: This Bit represents the MSB of the decimal value indicated in the description column.

## 7.16 Mode signals

The STPM1x includes four Mode signals. These signals change some of the operation of the STPM1x. The mode signals are not retained when the STPM1x supply is not available and then they are cleared when a POR occurs.

The mode signals bit can be written using the normal writing procedure of the CFGI interface (see CFGI par. 7.17)

**Table 15. Mode signals description**

Signal Name	Bit Value	Status	Binary Command	Hex Command
PUMP	0	MOP and MON operate normally	0111000x	70 or 71
	1	MOP and MON provide the driving signals to implement a charge-pump DC-DC converter	1111000x	F0 or F1
RD	0	The 56 Configuration bits originated by OTP anti-fuses	0111101x	7A or 7B
	1	The 56 Configuration bits originated by shadow latches	1111101x	FA or FB
WE	0	Any writing in the configuration bits is recorded in the shadow latches	0111110x	7C or 7D
	1	Any writing in the configuration bits is recorded both in the shadow latches and in the OTP anti-fuse elements	1111110x	FC or FD

- **RD** mode signal has been already described in par. 7.15 (configuring the STPM1x), but there is another implied function of the signal RD. When it is set, each sense amplifier is disconnected from corresponding anti-fuse element and this way, its 3V NMOS gate is protected from the high voltage of  $V_{OTP}$  during permanent write operation. This means that as long as the  $V_{OTP}$  voltage reads more than 3V, the signal RD should be set.
- **PUMP**. When set, the PUMP mode signal transforms the MOP and MON pins to act as driving signals to implement a charge-pump DC-DC converter (see [Figure 23](#)). This feature is useful in order to boost the  $V_{CC}$  supply voltage of the STPM1x to generate the  $V_{OTP}$  voltage (14 V to 20 V) needed to program the OTP anti-fuse elements.
- **WE** (write Enable): This mode signal is used to permanently write to the OTP anti-fuse element. When this bit is not set, any writing to the configuration bit is recorded in the shadow latches. When this bit is set, the writing is recorded both in the shadow latch and in the OTP anti-fuse element.

## 7.17 CFGI: Configuration interface

The CFGI interface supports a simple serial protocol, which is implemented in order to enable the configuration of STPM1x which allows writing the Mode bits and the configuration bits (temporarily or permanently);

Four pins of the device are dedicated to this purpose: SCS, SYN-NP, SCLNCN, SDATD.

SCS, SYN-NP, SCL-NLC and SDATD are all input pins. A high level signal for these pins means a voltage level higher than  $0.75 \times V_{CC}$ , while a low level signal means a voltage value lower than  $0.25 \times V_{CC}$ .

The condition in which SCS, SYN-NP and SCL-NLC inputs are set to high level determines the idle state of the CFGI interface and no data transfer occurs.

- **SCS**: in the STPM1X, the SYN-NP, SCL-NLC and SDA-TD have the dual task to provide information on the meter status (see Pin Description table) and to allow CFGI communication. The SCS pin allows using the above pins for CFGI communication when it is low and allows the normal operation of SYN-NP, SCL-NLC and SDA-TD

when it is high. In this section, the SYN-NP, SCL-NLC and SDA-TD operation as part of the CFGI interface is described.

- **SYN-NP**: this pin allows synchronization of the communication between STPM1x and the host. See [Figure 19](#) - for detailed timing of the pin.
- **SCL-NLC**: it is basically the clock pin of the CFGI interface. This pin function is also controlled by the SCS status. If SCS is low, SCL-NLC is the input of the serial bit synchronization clock signal. When SCS is high, SCL-NLC is also high which determines the idle state of the CFGI.
- **SDA-TD** is the Data pin. SDA-TD is the input of the serial bit data signal.

Any pin above has internal weak pull up device of nominal 15 A. This means that when a pin is not forced by external signals, the state of the pin is logic high. A high state of any input pin above is considered as an idle (not active) state. For the CFGI to operate correctly, the STPM1x must be correctly supplied as described in the Power Supply section. When SCS is active (low), signal SDA-TD should change its state at trailing edge of signal SCL-NLC and the signal SDA-TD should be stable at the next leading edge of signal SCL-NLC. The first valid bit of SDA-TD always starts with the activation of signal SCL-NLC.

### Writing procedure

Each writable bit (Configuration and Mode bits) has its own 6-bit absolute address. For the configuration bits, the 6-bit address value corresponds to its decimal value, while for the mode bits, the addresses are the ones indicated in the Mode Signal paragraph (7.16).

In order to change the latch state, a byte of data must be sent to STPM1x via CFGI. This byte consists of 1-bit data to be latched (msb), followed by 6-bit address of destination latch, followed by 1-bit don't care data (lsb) which totals 8 bits of command byte.

For example, if we would like to set the configuration bit 52 (additional gain of 8) to 1, we must convert the decimal 52 to its 6-bit binary value: 110100. The byte command will be then composed like this:

1 bit DATA value+6-bits address+1 bit (0 or 1) as depicted in [Figure 19](#) -. In this case the binary command will be 11101000 (0xE8) or 11101001 (0xE9).

**Figure 21. Timing for writing configuration and mode bits**

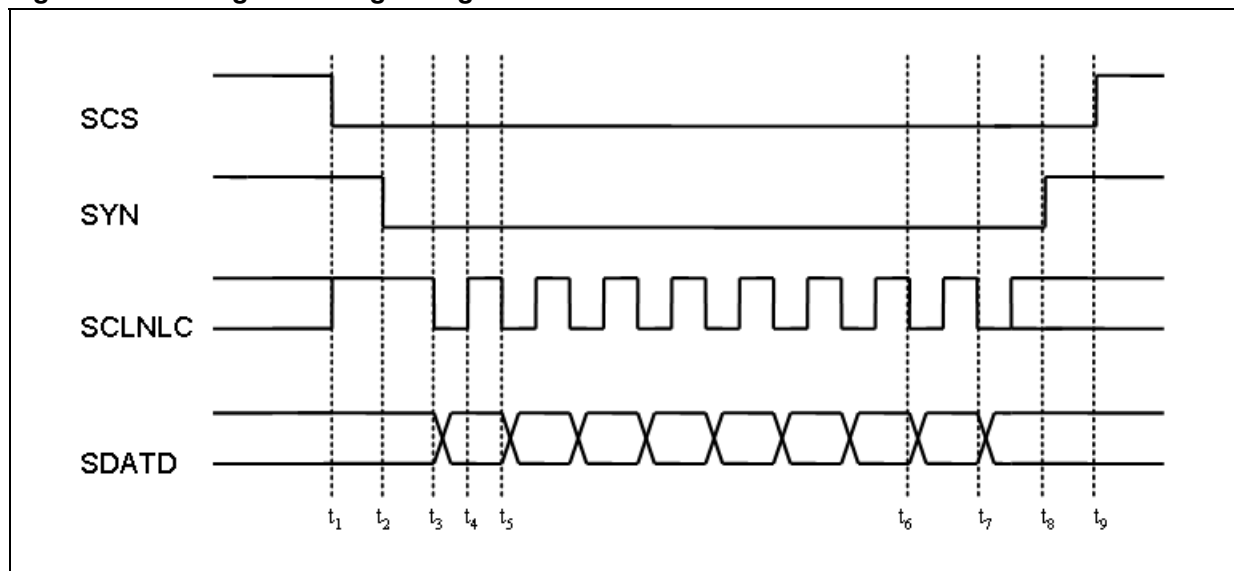

$t_1 \rightarrow t_2$  (>30ns): CFGI out of idle state  
 $t_2 \rightarrow t_3$  (>30ns): CFGI enabled for write operation  
 $t_3$ : data value is placed in SDA  
 $t_4$ : SDA value is stable and shifted into the device  
 $t_3 \rightarrow t_5$  (>10 $\mu$ s): writing Clock period  
 $t_3 \rightarrow t_5$ : 1 bit Data value  
 $t_5 \rightarrow t_6$ : 6 bits address of the destination latch  
 $t_6 \rightarrow t_7$ : 1 bit EXE command  
 $t_8$ : end of CFGI writing  
 $t_9$ : CFGI enters idle state

The same procedure should be applied for the mode signals, but in this case the 6-bits address must be taken from the [Table 14](#).

The lsb of command is also called EXE bit because instead of data bit value, the corresponding serial clock pulse is used to generate the necessary latching signal. In this way the writing mechanism does not need the measurement clock in order to operate, which makes the operation of CFGI module of STPM1x completely independent from the rest of the device logic except from the signal POR.

Commands for changing system signals should be sent during active signals SCS and SYN-NP as it is shown in the [Figure 19](#) -. A string of commands can be send within one period of active signals SCS and SYN-NP.

### Permanent writing of the CFG bits

In order to make a permanent set of some CFG bits, use the following procedure:

1. collect all addresses of CFG bits to be permanently set into a list;
2. clear all OTP shadow latches;
3. set the system signal RD;
4. connect a current source of at least +14V, 1mA to 3mA to VOTP;
5. wait for VOTP voltage to be stable;
6. set one OTP shadow latch from the list;
7. set the system signal WE;
8. wait for 300 s;
9. clear the system signal WE;
10. clear the OTP shadow latch which was set in step 6;
11. until all CFG bits are permanently set as desired, repeat steps 5 to 11;
12. disconnect the current source;
13. wait for VOTP voltage to be less than 3V;
14. clear the system signal RD;
15. verify the correct writing, testing STPM1x operation;
16. if the verification of CFG bits fails, repeat steps 1 to 16.

For steps of set or clear, apply the timing shown in [Figure 19](#) - with proper signal on the SDA-TD.

In order to create a permanent set of the TSTD bit, which does not result in any more writing to the Configuration bits, the procedure above must be conducted in such a way that steps 6



to 13 are performed in series during a single period of active SCS. The idle state of SCS would make the signal TSTD immediately effective which in turn, would abort the procedure and possibly destroy the device due to clearing of system signal RD. This would result in the connecting of all gates of 3 V NMOS sense amplifiers of already permanently set CFG bits to the  $V_{OTP}$  source.

## 8 Energy calculation algorithm

Inside the STPM1x the computing section of the measured active power uses a completely new patented signal process approach. This approach allows the device to reach high performances in terms of accuracy.

The signals, coming from the sensors, for the instantaneous voltage is:

$$v(t) = V \cdot \sin \omega t; \text{ where } V \text{ is the peak voltage and } \omega \text{ is related to the line frequency (see[1])}$$

and the instantaneous current is:

$$i(t) = I \cdot \sin (\omega t + \phi); \text{ where } I \text{ is the peak current, } \omega \text{ is related to the line frequency and } \phi \text{ is the phase difference between voltage and current (see[2])}$$

### Active power

Figure 22. Active energy computation diagram

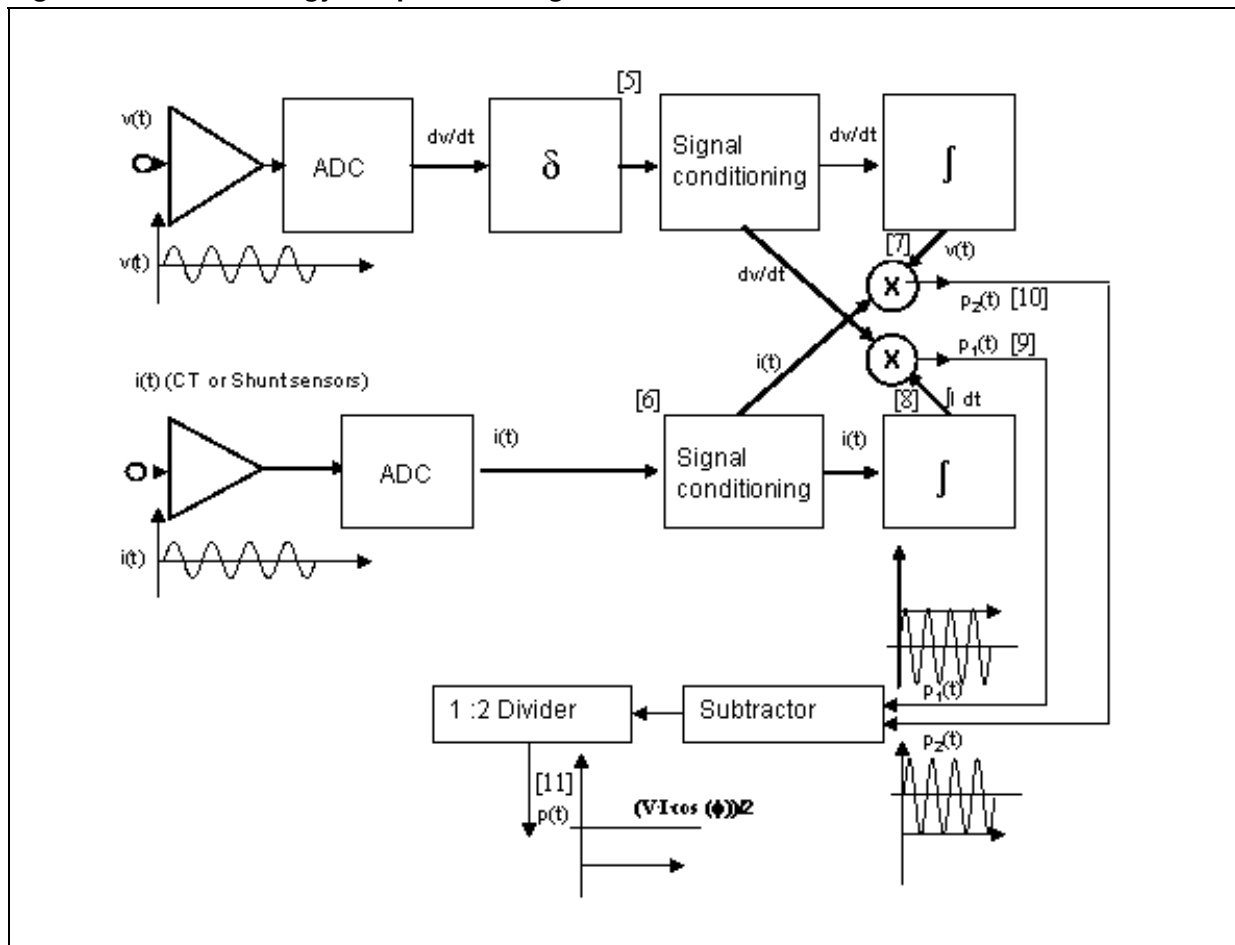

In the STPM1x, after the pre-conditioning and the A/D conversion, the digital voltage signal (which is dynamically more stable with respect to the current signal) is processed by a differentiate stage which transforms:

$$v(t) \rightarrow v'(t) = dv/dt = V \cdot \omega \cdot \cos \omega t - [\text{Eq. 1 - see (5) in Figure 6}]$$

The result, together with the pre-processed and digitalized current signal:

$i(t) = I \cdot \sin(\omega t + \varphi)$ ; [Eq. 2 - see (6) in [Figure 6](#)]

can then be used to calculate. These digital signals are also used in two additional steps for integration, obtaining:

$\frac{dv}{dt} \rightarrow v(t) = V \cdot \sin \omega t$  [Eq. 3 - see (7) in [Figure 6](#)]

$$i(t) \cdot I(t) = \int i(t) \cdot dt = -\frac{I}{\omega} \cdot \cos(\omega t + \varphi)$$

[Eq. 4 - see (8) in [Figure 6](#)]

Now four signals are available. Combining (pairing) them by two multiplication steps two results are obtained:

$$p_1(t) = \frac{dv}{dt} \cdot \int i(t) \cdot dt = -\frac{V \cdot I \cdot \cos \varphi}{2} - \frac{V \cdot I \cdot \cos(2\omega t + \varphi)}{2}$$

[Eq. 5 - see (9) in [Figure 6](#)]

$$p_2(t) = v(t) \cdot i(t) = \frac{V \cdot I \cdot \cos \varphi}{2} - \frac{V \cdot I \cdot \cos(2\omega t + \varphi)}{2}$$

[Eq. 6 - see (10) in [Figure 6](#)]

After these two operations, another stage another step involves the subtraction of  $p_1$  from  $p_2$  and dividing the result by 2, to obtain the active power:

$$p(t) = \frac{(p_2(t) - p_1(t))}{2} = \frac{V \cdot I \cdot \cos \varphi}{2}$$

[Eq. 7 - see (11) in [Figure 6](#)]

In this way, the AC part

$$\left( \frac{V \cdot I \cdot \cos(2\omega t + \varphi)}{2} \right)$$

has been then removed from the instantaneous power.

In the case of current sensors like "Rogowski coils", which provide the rate of the instantaneous current signal, the initial voltage signal differentiation stage is switched off. In this case the signals coming from the A/D conversion and their consequent integrations are:

$v(t) = V \cdot \sin(\omega t)$ ; [Eq. 8]

$$i'(t) = \frac{di(t)}{dt} = -I \cdot \omega \cdot \cos(\omega t + \varphi)$$

[Eq. 9]

$$V(t) = \int v(t) \cdot dt = -\frac{V}{\omega} \cdot \cos \omega t$$

[Eq. 10]

$$i''(t) = \int i'(t) \cdot dt = i(t) = -I \cdot \sin(\omega t + \varphi)$$

[Eq. 11]

The signals process flow is the same as shown in the previous case, and even with the formulas above, the result is the same.

The absence of any AC component allows a very fast calibration procedure. Averaging the readings of several line periods is not needed. The active energy measurement is already stable after one line cycle. Moreover the digital calibration allows saving time and space compared to the hardware calibration made with resistor strings.

## 9 STPM1x calibration

Energy meters based on STPM1x devices are calibrated on the frequency of the output pulse signal.

The devices are comprised of two independent meter channels for line voltage and current respectively. Each channel includes its own digital calibrator, to adjust the voltage and current signals coming from the sensors in the range of  $\pm 12.5\%$  in 256 steps. A digital filter is included to remove any signal DC component.

The devices produce an energy output pulse signal whose frequency is proportional to the measured active energy.

The devices have an embedded memory, 54 bits, used for configuration and calibration purposes. The value of these bits can be written temporarily or permanently through CFGI communication channel.

The basic information needed to start the calibration procedure is found in [Table 16](#) and [Table 17](#):

**Table 16. Calibration entries**

Symbol	Description	Value
Vn	Line RMS voltage	(230 V)
In	Line RMS current	(5 A)
P	Power sensitivity	(LED: $P=128000$ pulses/kWh, Stepper Motor: $PM=P/64= 2000$ pulses/kWh)
Si	Shunt Sensor	0,42 mv/A

The following typical STPM01 parameters and constants are also known:

**Table 17. Device calculation constants**

Symbol	Description	Value
Vbg	Reference voltage	(1.23 V $\pm 2\%$ )
fM	Clock	( $2^{23}$ Hz $\pm 50$ ppm)
Av, Ai	Amplification of ADC	( $4 \pm 1\%$ , (8, 16, 24, 32) $\pm 2\%$ )
Gp	Gain of voltage and current decimation filters	(0.504008)
Cv, Ci	Calibration data range	(min = 0, ini = 128, max = 255)
DL	AW Bit position that generates LED signal	( $2^{11}$ )

Av is constant. While, Ai is chosen according to the sensor

Gv and Gi are constant

Cv and Ci are 8bits register (CHV, CHP and CHS)

From the values above and for both the given amplification factor and initial calibration data, the following target values can be calculated:

Considering that Ci=0 generates a correction of 75% and that Ci=128 determines a correction factor of 87.5%, and the same for Cv, the total correction for the power stands within  $Kp = Kv \cdot Ki = (0.75 \cdot 0.75) = 56.25\%$  and 100%, and Cv=Ci=128 gives a correction factor of  $Kp = (0.875 \cdot 0.875) = 76.5625\%$

Each calibrator value can be changed from a binary form to a decimal correction form, using the following formula:

$$K_v = (C_v/128) * 0.125 + 0.75 \text{ and the same for } K_i.$$

Let us choose as initial value  $A_i = 32$

**Table 18. Calibration results**

Description	Value
Value of Calibrator	$K_p = K_v * K_i = 0.765625$
Frequency at LED	$f = P * \ln * V_n / 3600000 = 40.8889 \text{ Hz}$
Voltage divider	$S_v = (F * DL * V_{bg}^2) / (f_M * V_n * \ln * G_v * G_i * K_p * A_i * A_v * S_i) = 0,6324 \text{ mV/V}$
Voltage divider resistor	$R_1 = R_2 * (1000 / S_v - 1)$

From the target power constant  $C_p$  of the meter and the actual values of  $V_{RMS}$  and  $I_{RMS}$ , which are applied to the meter under calibration, the error of power measurement can be calculated:

$$\text{err} = 100(f_x/f - 1) [\%], \text{ where } f_x \text{ is the real frequency read at LED output.}$$

Now, a final unit less power reduction factor can be calculated:

$$p_F = (p_D - \text{err}) / 100$$

This final power reduction factor can be considered as a product of voltage and current reduction factors which are produced from corresponding calibration constants. So, an obvious solution to obtain the voltage and current reduction factors is to calculate a common reduction factor as a square root of  $p_F$ . This result must fall within the indicated range, otherwise the device cannot be calibrated:

$$768 \leq R = 1024 \text{ pF} + 0.125 < 1024$$

In order to obtain the corresponding calibration constants, the reduction factor must be transformed:

$$CV = CC = R - 768$$

By using separately the integer and the fractional part of the common reduction a better fit of calibration constants can be produced. Simply, let's set one of the two calibration registers (e.g. CV) to the lowest integer value of R, while the other (CC) should be set to the nearest integer value of R. Examples:

$$R - 768 = 128.124; \text{ in this case set } CV = 128; \text{ set } CC = 128$$

$$R - 768 = 127.755; \text{ while in this other one set } CV = 127; \text{ set } CC = 128.$$

**Note:** *STPM13/14: each current channel must be calibrated separately. In order to do this, follow these steps:*

*Apply the nominal test voltage to the voltage sensor, and the nominal test current to the primary current channel sensor. Do not apply such current on the secondary current channel sensor.*

*Adjust the voltage and primary current calibrators (see above).*

*Disconnect the nominal test current from the primary current channel sensor, and apply it to the secondary current channel sensor.*

*Adjust only the secondary current calibrators, so that the same power is computed.*

# 10 Schematic

Figure 23. Charge pump schematic

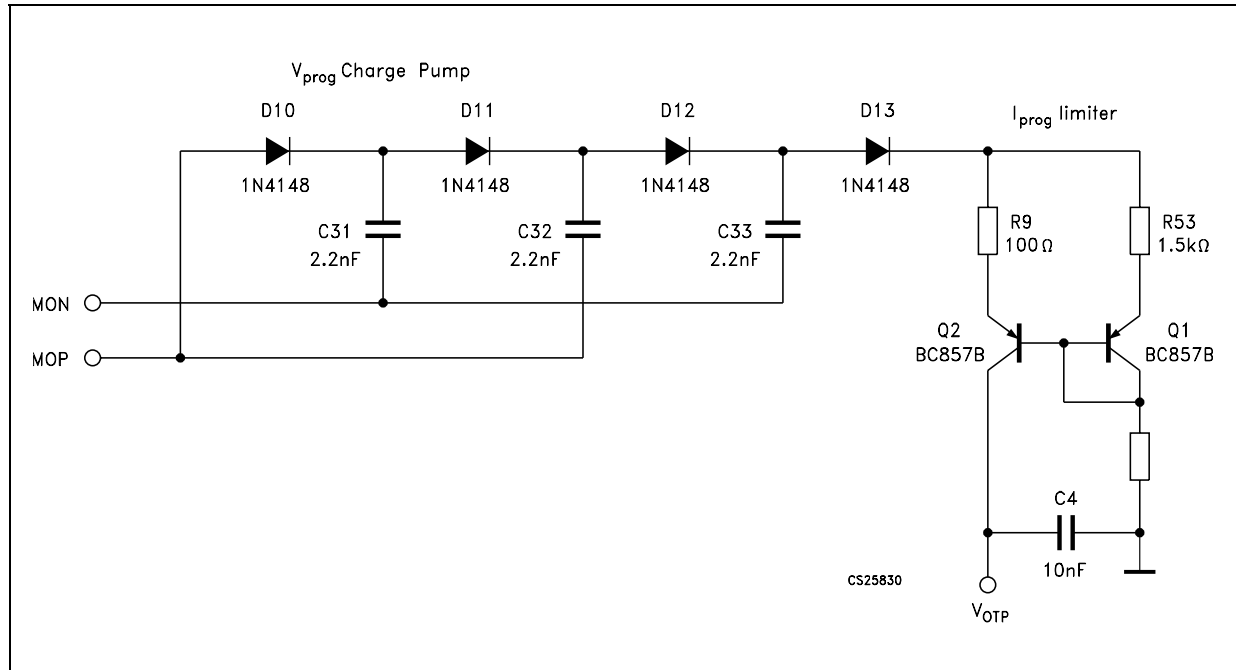
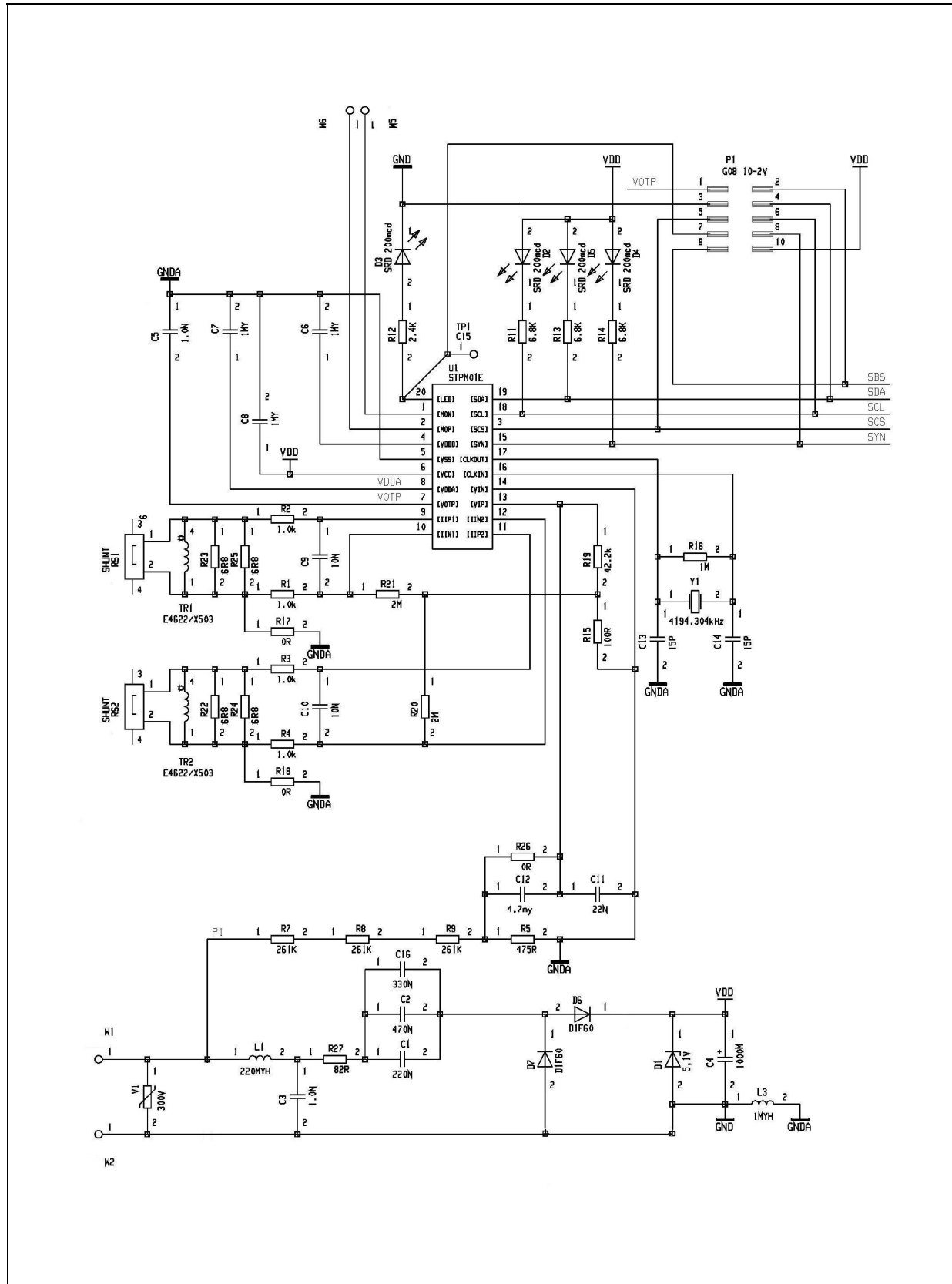

Figure 24. Application schematic





## 11 Package mechanical data

In order to meet environmental requirements, ST offers these devices in ECOPACK® packages. These packages have a lead-free second level interconnect. The category of second Level Interconnect is marked on the package and on the inner box label, in compliance with JEDEC Standard JESD97. The maximum ratings related to soldering conditions are also marked on the inner box label. ECOPACK is an ST trademark. ECOPACK specifications are available at: [www.st.com](http://www.st.com).

**TSSOP20 mechanical data**

Dim.	mm.			inch.		
	Min.	Typ.	Max.	Min.	Typ.	Max.
A			1.2			0.047
A1	0.05		0.15	0.002	0.004	0.006
A2	0.8	1	1.05	0.031	0.039	0.041
b	0.19		0.30	0.007		0.012
c	0.09		0.20	0.004		0.0079
D	6.4	6.5	6.6	0.252	0.256	0.260
E	6.2	6.4	6.6	0.244	0.252	0.260
E1	4.3	4.4	4.48	0.169	0.173	0.176
e		0.65 BSC			0.0256 BSC	
K	0°		8°	0°		8°
L	0.45	0.60	0.75	0.018	0.024	0.030

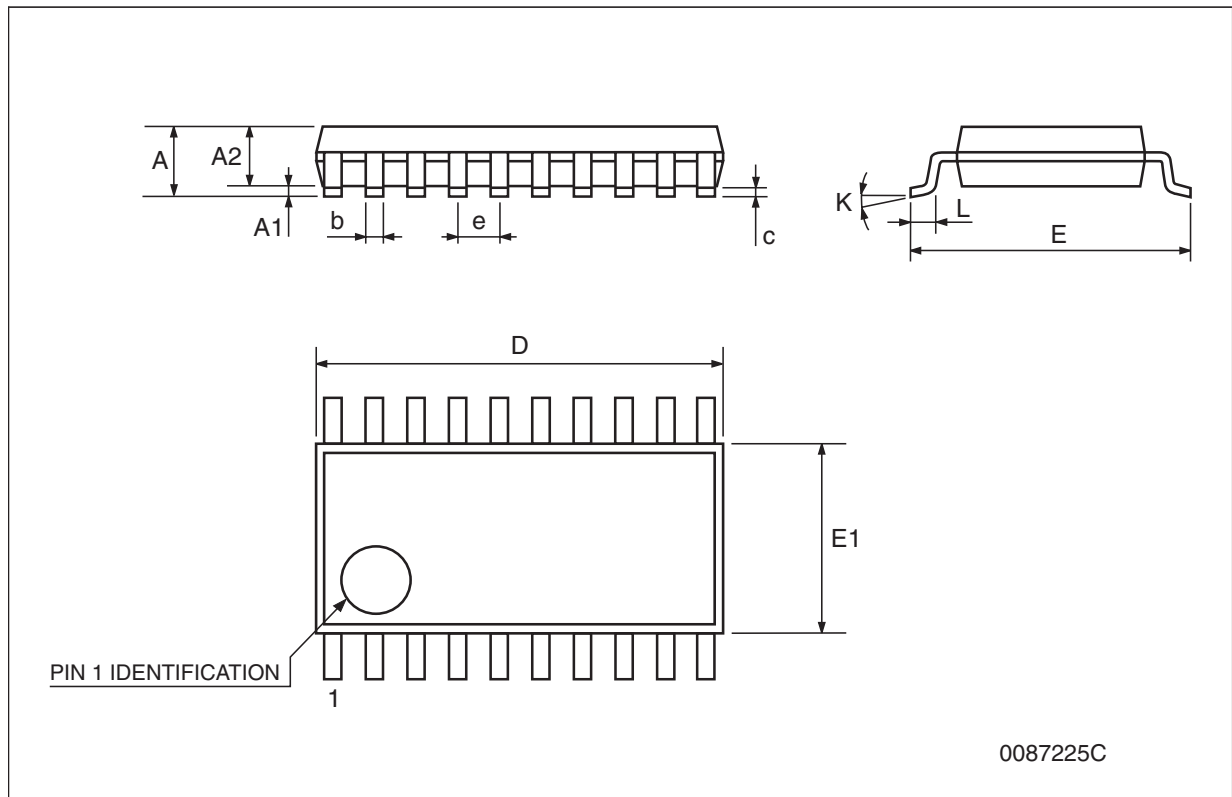

**Tape & reel TSSOP20 mechanical data**

Dim.	mm.			inch.		
	Min.	Typ.	Max.	Min.	Typ.	Max.
A			330			12.992
C	12.8		13.2	0.504		0.519
D	20.2			0.795		
N	60			2.362		
T			22.4			0.882
Ao	6.8		7	0.268		0.276
Bo	6.9		7.1	0.272		0.280
Ko	1.7		1.9	0.067		0.075
Po	3.9		4.1	0.153		0.161
P	11.9		12.1	0.468		0.476

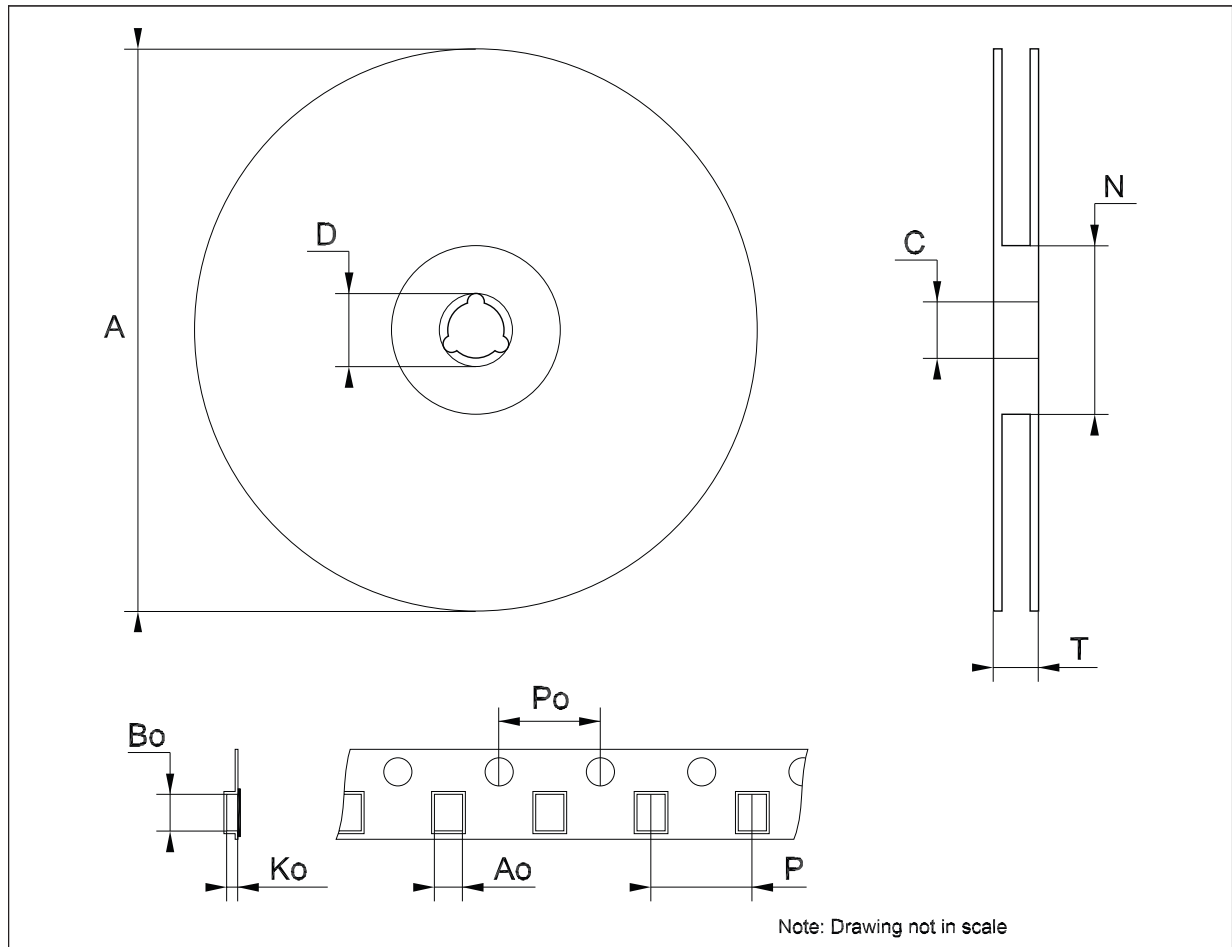

## 12 Revision history

**Table 19. Document revision history**

Date	Revision	Changes
30-Jan-2007	1	Initial release.
06-Feb-2007	2	The <i>Figure 11</i> has been changed.
20-Mar-2007	3	General description has been updated.
13-Sep-2007	4	Add <i>Table 1</i> in cover page.
21-Jan-2008	5	Added <i>Note: on page 38</i> .

**Please Read Carefully:**

Information in this document is provided solely in connection with ST products. STMicroelectronics NV and its subsidiaries ("ST") reserve the right to make changes, corrections, modifications or improvements, to this document, and the products and services described herein at any time, without notice.

All ST products are sold pursuant to ST's terms and conditions of sale.

Purchasers are solely responsible for the choice, selection and use of the ST products and services described herein, and ST assumes no liability whatsoever relating to the choice, selection or use of the ST products and services described herein.

No license, express or implied, by estoppel or otherwise, to any intellectual property rights is granted under this document. If any part of this document refers to any third party products or services it shall not be deemed a license grant by ST for the use of such third party products or services, or any intellectual property contained therein or considered as a warranty covering the use in any manner whatsoever of such third party products or services or any intellectual property contained therein.

**UNLESS OTHERWISE SET FORTH IN ST'S TERMS AND CONDITIONS OF SALE ST DISCLAIMS ANY EXPRESS OR IMPLIED WARRANTY WITH RESPECT TO THE USE AND/OR SALE OF ST PRODUCTS INCLUDING WITHOUT LIMITATION IMPLIED WARRANTIES OF MERCHANTABILITY, FITNESS FOR A PARTICULAR PURPOSE (AND THEIR EQUIVALENTS UNDER THE LAWS OF ANY JURISDICTION), OR INFRINGEMENT OF ANY PATENT, COPYRIGHT OR OTHER INTELLECTUAL PROPERTY RIGHT.**

**UNLESS EXPRESSLY APPROVED IN WRITING BY AN AUTHORIZED ST REPRESENTATIVE, ST PRODUCTS ARE NOT RECOMMENDED, AUTHORIZED OR WARRANTED FOR USE IN MILITARY, AIR CRAFT, SPACE, LIFE SAVING, OR LIFE SUSTAINING APPLICATIONS, NOR IN PRODUCTS OR SYSTEMS WHERE FAILURE OR MALFUNCTION MAY RESULT IN PERSONAL INJURY, DEATH, OR SEVERE PROPERTY OR ENVIRONMENTAL DAMAGE. ST PRODUCTS WHICH ARE NOT SPECIFIED AS "AUTOMOTIVE GRADE" MAY ONLY BE USED IN AUTOMOTIVE APPLICATIONS AT USER'S OWN RISK.**

Resale of ST products with provisions different from the statements and/or technical features set forth in this document shall immediately void any warranty granted by ST for the ST product or service described herein and shall not create or extend in any manner whatsoever, any liability of ST.

ST and the ST logo are trademarks or registered trademarks of ST in various countries.

Information in this document supersedes and replaces all information previously supplied.

The ST logo is a registered trademark of STMicroelectronics. All other names are the property of their respective owners.

© 2008 STMicroelectronics - All rights reserved

STMicroelectronics group of companies

Australia - Belgium - Brazil - Canada - China - Czech Republic - Finland - France - Germany - Hong Kong - India - Israel - Italy - Japan - Malaysia - Malta - Morocco - Singapore - Spain - Sweden - Switzerland - United Kingdom - United States of America

[www.st.com](http://www.st.com)